

E&MM

SPECTRUM

SYNTHESISER



Part I (page 2)
Description & Notes

Part II (page 20)
Figures & Parts Lists

The E&MM Spectrum Synthesiser

The Spectrum is a monophonic two oscillator switch-linked synthesiser featuring advanced specification, constructional simplicity and low cost. Modulation, timbre control, and interface facilities not found on any comparable synthesiser make it extremely powerful and versatile for keyboard playing, sound effects and many other home, stage, or studio applications.

Construction is simplified by the use of integrated circuits that each perform major synthesiser functions with few external components. No glueing of contact blocks or bending of gold wires is needed to assemble the keyboard contacts; a new contact system only requires soldering of the contacts and drilling of the chassis to mount the contact PCB.

General description – how the Spectrum works

Figure 1 shows a **block diagram** of the synthesiser and the front panel legending is reproduced below. Modulation routing is accomplished by source and function switches and depth controls, rather than the usual method of providing each source with its own depth for each controlled function found on some small synthesisers. Switching is most suitable for a large number of sources as here, and allows fast selection of source and selection of modulation effects with preset depths, in favour of simultaneous modulation of one parameter by more than two signals. Six modulation signals are available: keyboard, controller, low frequency oscillator (LFO), envelope generator, noise generator and external.

The keyboard is of the highest note priority type and has a glide which always completes even after the key is released - this makes the keyboard much more useful as a controller for effects sounds. The joystick controller routes a voltage dependent on the side-to-side position of the stick to various voltage controlled circuits, allowing it to be used to control the pitch (pitch

bend) or timbre. The external voltage fed into the controller jack can override or add to the joystick voltage for control by additional synthesiser equipment, or a pedal can be plugged in and used for control by attenuating a fixed joystick voltage.

The low frequency oscillator generates random and regular sample and hold effects in addition to the four common waveforms. The regular S/H option allows rising and falling scales, rising and falling repeating groups of two, three or more notes, and other sequencer like effects, with the pattern controlled by the LFO rate. A LED displays the LFO cycle and the joystick's vertical position determines the amplitude at the LFO manual output. The envelope generator is of the exponential ADSR type and, like the LFO, has + and - outputs that can be separately selected for each controlled parameter. The envelope generator shares its gate signal with the envelope shaper, which determines the loudness contour of each note. 'Single' on the gate selector switch causes gating each time a first key is depressed; 'Multiple' retriggers when any new note is played, allowing fast runs without 'missed' notes. 'Hold' keeps the gate high for continuous effects, and 'LFO' causes gating on each LFO cycle. In the 'Repeat' position the envelope generator retriggers at the end of the decay period, acting as an additional LFO with variable symmetry. This allows complex rhythmic effects when used with the LFO, and gives great scope for 'backdrop' sounds based around complex S/H patterns with periodic timbre sweeping effects derived from the EG. 'Key Repeat' brings in the repeat only when a key is held, allowing key synchronised repeating notes and delayed modulation (the delay determined by the attack time). An LED indicates the EG's attack segment.

The voltage controlled oscillators (VCOs) each have six switched octave ranges and five waveforms. The sub octave output is a pulse wave with a square wave added an octave below, making the sound fuller and richer. The tuning LED detects the beats between the oscillators, and indicates when the pitches are in simple musical intervals, useful for tuning without sounding a note (e.g. on stage). The pulse width of VCO 1 is variable, and VCO 2 has a tune control with a tune fifth range.

The VCOs can be used together to provide a vast range of sounds not possible with basic synthesisers having only waveform, shape, VCF cutoff and VCF resonance as the controls affecting basic timbre. This is done by frequency modulation and synchronisation - special features of this design. FM uses the triangle output of VCO 1 to modulate the frequency of VCO 2 up to + /- 100%, giving a whole range of non-harmonic tones for bell, gong and chime sounds etc. Synchronisation gives various waveforms from VCO 2 (see **Figure 2**) which have particular bands of harmonics emphasised for strong, voice box-like sounds. This is achieved by resetting the output of VCO 2 upon each cycle of VCO 1, so the tones generated are always harmonic.

Two modes of sync. are provided: Sync. I is that normally found on rampwave oscillators, the VCO 2 waveform beginning in the same way after each reset; Sync. II is something totally new - the triangle output is set to mid way each time but then carries on in the same direction in the new cycle. VCO 2 locks on to VCO 1 harmonics with the change from one harmonic to the next emphasised by a sharp change in tone. This enables automatic arpeggiation and incredible tone sweeps to be obtained since VCO 2 now is effectively a voltage controlled waveform generator/frequency multiplier.

The sync. control attenuates the pulses fed to VCO 2 so that it only resets if the wave form is above a certain threshold, resulting in the oscillators being locked together in musical intervals (3rds, 5ths etc). Simultaneous Sync. I and FM produces harmonic tones with the shape of FM-ed waveforms within each cycle.

The ring modulator uses triangle and square VCO waveforms to provide further complex tones. Its output is mixed with the noise signal and fed into a special voltage controlled amplifier (VCA). This can be controlled by the LFO or EG, and gives the signals their own loudness contours. Hence noise 'chiffs' can be added to notes, or ring modulation set to swell in as a note decays.

The VCA output is fed to the voltage controlled filter (VCF) mixed with the VCO outputs. The VCF offers the two most useful responses, low

pass and band pass, plus an intermediate response for bright sounds that remain strong in lower harmonics. Cutoff frequency and resonance controls perform their normal functions and a keyboard follow control determines how the cutoff frequency varies over the keyboard range. After envelope shaping, the signal is fed to the voltage controlled pan circuit which can modulate the location of the sound in the stereo field by the LFO or EG signals. The stereo outputs can also be used for voltage control of the depth of external effects such as reverb, phase, and echo, by routing one signal via the effects unit and one direct to the amplifier. A mono output is also provided, and the VCA can also be used for additional amplitude modulation with the LFO as source (for tremolo and other effects).

The interface jacks allow connection to external devices such as sequencers, additional VCO banks, waveform processors etc. The Spectrum Synthesiser uses the 1V/octave CV standard, and can be interfaced to any other exponential CV synthesiser.

Keyboard

The Spectrum uses a unique key contact system which is cheaper, more reliable, and easier to construct than alternatives using gold-plated wire and contact blocks. A single moving contact is used for each key with all contacts and their associated divider chain resistors held on a PCB (in two parts) fixed to the keyboard chassis.

The moving contacts are silverplated springs, each fixed at one end and moved at the other by the plunger of the respective key such that the spring makes contact with two palladium bars when the key is depressed (**Figure 3**).

The first bar is connected to the sample and hold circuit which stores the voltage representing the last key depressed, and the second to a circuit which generates a gate signal for the S/H and the envelope generators. The moving contacts connect to the divider chain (see **Figure 4**). These functions are usually carried out by separate contact pairs, where unless the contacts are precisely set up, note-jumping will occur when the envelope is gated before the S/H

receives the new key voltage. The system used here is immune from this since the construction ensures the correct sequence of operation, and no initial setting up is required. The keyboard recommended in the parts list has removable key plungers so that cleaning the contacts is much easier too. Unclipping a plunger allows access to the sides of the bars and springs that meet.

Power Supply Unit

The proper operation of synthesiser circuits requires a stable, noise-free supply, so it is important that the Power Supply Unit (PSU) is well regulated and has current in reserve. The Spectrum PSU uses monolithic regulators and low temperature coefficient components in a dual design to provide +15V at 270 mA maximum. The Power Supply Unit consists of two identical circuits providing the positive and negative supplies, driven by a dual secondary transformer. Each secondary produces about 21V when the AC signal is rectified and smoothed, and is fused for protection in the event of a power supply fault. Regulation is carried out by the well-known μ A723 regulator IC which is used with an external power transistor in series pass mode to provide the required current. This current limits at 270 mA when the voltage across series resistor R1 (R2 in the -ve side) reaches 0.6V. RV1 (RV2) allows the rail voltage to be adjusted to exactly 15V, and D1 (D2) protects against reverse polarity, again in the event of a fault. The +15V regulated output of the side based around IC2 is connected to 0V of the IC1 side, giving the -15, 0, +15V supply rails.

Keyboard Controller

Figure 6 shows the circuit diagram of the keyboard controller. Connections 1 and 2 are the bottom and top respectively of the keyboard divider chain. This is arranged in the feedback loop of IC3a, which drives a current of about 1.8mA through the divider chain. This generates 83mV across each divider chain resistor, corresponding to a semitone, and 1V across each group of twelve, corresponding to an octave. R58 and R59 drop 1.7V so the

range of key voltage is 1.7 (top C) to 5.7V (bottom C). R57 and RV3 determine the current, RV3 allowing it to be trimmed for exactly 1V/octave.

IC3b generates a signal that is used, after processing, to gate the envelope generators and key voltage sample and hold. With no keys depressed, the non-inverting input is held at 0V by R60 and since the inverting input is at +0.83V (determined by R58) IC3b's output is at its negative extreme, almost -15V. When a key is depressed, the voltage at the inverting input rises to between 1.7 and 5.7V since the gate bus-bar is connected to the divider chain by the contact of the depressed key, and the output of IC3b goes high.

TR3 is a FET which acts as a voltage controlled switch in the sample-and-hold circuit around C11. It is normally held off by the negative output voltage of IC3b, via R62 and D14, but upon this going positive it is turned on and C11 charges to the voltage on the S/H bus-bar (connection point 3). Since the contact spring makes with this before the gate bus-bar the new key voltage is always ready for sampling by the time the FET is turned on. IC5 is a FET input op-amp with a very low input bias current. This ensures that when the key is released and TR3 turns off the charge on C11 is retained with the minimum of 'droop'. Even when C11 is a high quality type (as it must be), leakage in this component predominates over the input current of IC5a. On the prototype, it took about 15 minutes for middle A to drift up to A#. With the output of IC3b low, C10 is kept charged by D11, but when a key is depressed it is allowed to discharge through R65 and R66. It takes approximately 2m5 for the voltage to reach the threshold of the Schmitt NAND gate IC6a, the output of which then goes low. Since D11 charges C10 very fast upon the comparator output going low, it must remain high for at least 2m5 for the gate signal to be passed on to IC6b. This ensures that the effect of contact bounce upon key depression or release is eliminated and cannot cause false triggering of the envelope generators.

The external gate signal is inverted by TR4 and NAND-ed with the output of IC6a to give the key gate signal which is sent to the EGs.

If a new note is played on the keyboard before the previous one is released, a new CV is generated, but since the key gate signal remains high, the EGs will not restart their envelopes. This can be a problem when percussive envelopes are used, fast keyboard runs giving missed notes. The problem is eliminated by detecting a change in CV at the sample and hold output, and generating a key retrigger signal for the EGs. IC4a is a high-gain differentiator that produces a pulse for each change in the value of the CV. These pulses are rectified and squared up by the comparator IC4b, and lengthened by D16, R75, and C12 to a minimum of 5mS. Contact bounce produces a very ragged CV change when a note is depressed while one is already down, and this in turn produces a multiple pulse at the output of IC4b. The circuit around IC6c generates a clean 500uS pulse from this signal - most important for external devices such as sequencers which count in response to triggers from the keyboard. When the charge on C12 reaches the threshold of IC6c, the output goes high and C14 charges via D18 and R85. After 500uS, C14 also reaches the required level, the output is forced low, and C14 begins to discharge slowly through R81. For 30mS after each pulse C14 inhibits IC6c so that no more pulses can occur at the output during this period.

Since the sample-and-hold voltage is updated before the key gate starts, a first key depression would cause an unwanted pulse on the key retrigger line. This is eliminated by D17, which holds the input of IC6d high until the gate is received.

The de-bounced gate signal from IC6a is inverted by TR5, which drives the 'key gate out' interface jack. D19 causes the gate out signal to go low in response to the key retrigger signal. TR5 is arranged to pull the output to +15V to generate the gate signal - this system allows gates from different sources to be connected together, providing an OR-function that gates the controlled device if any source signal is high.

The output of the sample and-hold circuit (TR3, C11, IC5a) is passed to the glide circuit (R74, RV4, C13, IC5b) which produces sweeps between successive notes. The time taken for a new note voltage to be reached is controllable from

almost instantaneous to five seconds for one octave by RV4. IC5b is a low input bias current op amp, avoiding any voltage drop across RV4 that would cause a perceptible pitch error with maximum glide.

Low Frequency Oscillator

The Low Frequency Oscillator (LFO) of a synthesiser provides periodic waveforms for the control of other modules to produce modulation of pitch, timbre, amplitude etc. When the synthesiser is being used other than for a simple melodic playing, the LFO is often the main control source, and must have a wide frequency range and a choice of precise waveforms. The Spectrum LFO has a range of over 1000:1, from 0.04 Hz (25 seconds per cycle) to about 42Hz. Sine, triangle, ramp, and square waveforms are available, plus two additional step-type waveforms, one giving a new random voltage on each cycle, the other producing a wide range of repeating sequences. A LED flashes to indicate the LFO cycle and is very useful for quickly checking or setting the rate.

Particular attention has been paid to waveform precision, and good symmetry is retained over the frequency range. Unlike many other designs, no setting up is required.

Circuit (of LFO)

Figure 8 shows the circuit of the LFO. It is based around IC8, IC9a, TR8, 9, 16 and 17, which form a precision triangle and square wave generator. IC8 is an integrator driven by the voltage at the wiper of RV6, the Rate control.

A low input bias current op amp must be used for IC8 to preserve wave form symmetry since a bipolar device would drain the input current significantly at low frequencies, causing different charge and discharge rates for C16.

IC9a is a comparator which reverses the voltage at the integrator input when its output reaches thresholds set by R100 and 101, so the integrator output ramps up and down between fixed levels generating a triangle wave. IC9a drives TR8, 9, 16 and 17 which are confi-

gured as an additional complementary pair output stage driving the integrator, and from which feedback to IC9a is obtained. Since this stage is non-inverting and R101 takes the signal back to the non inverting input of IC9a the feedback is positive, causing the output to be either high or low and giving the comparator hysteresis. An additional output stage is used because the maximum and minimum output voltages of the op-amp are unpredictable and rarely symmetrical. This would give unequal times for the two halves of the cycle and waveforms which were not precisely symmetrical about 0V, since the thresholds are derived from the output of the comparator circuit.

The method of producing the ramp wave is rather unusual. The triangle and square waves are mixed and half wave rectified by IC9b. Since only positive output values are allowed, the signal is 'cut off' at zero volts when the square wave is high i.e. when the triangle wave is falling. The result is a positive going half-wave rectified ramp wave, which gives a complete ramp wave when the triangle wave (and an offset) is added, producing a slope during the 'flat' half cycle and half-cancelling the slope during the other half.

The sine wave is generated by D24-27 and associated resistors. Minimum harmonic content of a sine wave used for control purposes is not as important as smoothness of the waveform - it should have no sharp changes of gradient and should slow down gradually towards the peaks. This is achieved by two parallel diode shaping networks which act on the triangle wave. As the voltage increases on positive half cycles, D25 conducts first, and then D26 conducts just before the peak, with D24, 27 acting on negative halves. The sine wave is produced by mixing the two components by R126, 128 at IC10b. S2b selects the output waveform, with IC10b and its input resistors mixing the components for the ramp and sine waves and ensuring that all waveforms have the same level. The output of IC10b is the '+LFO' signal, and this is inverted by IC12a to give '-LFO'.

The 'LFO MAN' output gives the selected waveform at a level controlled by the joystick y-axis. RV7 is the joystick pot, acting as potential divider fed by +LFO and buffered by IC12b. Since

the joystick needs to move in both directions, there will be an indeterminate amount of LFO signal on the wiper of RV7 when the stick is central. RV8 cancels this signal out by introducing the same polarity signal to the inverting input of IC12b. This means that moving the joystick one way will give an increasing +LFO signal on the LFO MAN output, while the other direction will give -LFO.

The regular and random LFO wave forms are step type functions which change level abruptly at the beginning of each cycle and remain fixed until the next cycle starts. They are produced by the sample and hold circuit around C19 and differ in the type of input to the sample and hold (S/H). The random waveform has the output of the noise generator as its source, producing a new random voltage in the range $\pm 2.5V$ every cycle. The regular waveform is more complicated since the source is periodic - a 20Hz ramp wave which is synchronised to the main LFO. This is generated by the oscillator around TR6, 7 and C15. TR6 is a constant current source linearly charging C15. When the voltage on C15 reaches +5V, TR7, a unijunction transistor, turns on and discharges it to -10V via R97, from where it begins to charge again. With the regular waveform output selected, S2a connects C15 to IC10a, which buffers the ramp wave signal. TR10 is the S/H switch, normally kept off by TR11 which holds its gate negative. Upon the LFO square wave going negative at the beginning of a cycle the pulse from C18 turns TR11 off and TR10 is allowed to conduct. C19 charges to the value of the input signal, and at the end of the sample period, which lasts about 1 ms, TR10 turns off again and the charge on C19 is held until the next sample. IC11 is a FET-input op-amp connected as a voltage follower, buffering the voltage on the capacitor. A low input bias current device is necessary to minimise the drain on C19, achieving a low voltage 'droop' between successive samplings.

The output of IC11 is fed to IC10b where the S/H waveform can be selected by S2b, with the values of R114, R115 chosen to produce a $\pm 2.5V$ output signal from the -10, +5V range of the sampled voltage. With S26 in the 'Random' position, the signal is low pass filtered by R116 and C20 which remove the burst of noise

that appears while the sample-and hold FET is on. Though this is only 1ms long, it could break through into the audio chain when using large modulation depths of VCF cutoff frequency or VCA amplitude.

The effect of sampling a constant frequency rampwave at a regular rate is to produce complex repeating sequences of voltages, the sequence length and type being determined by the sampling and sampled frequencies. This is often used to produce note sequences by modulating a VCO with the sample and hold output, but suffers from the disadvantage that the slightest change in sampling frequency or the frequency of the sampled wave form changes the effect. In practice it is very difficult to get a precisely repeating sequence, rather than one which has a repetitive theme that steadily changes as a part of a truly repeating sequence with a much longer period. In other words, the results are often too complex and uncontrollable to be useful, and some method is needed to restrict the S/H waveform to shorter repeating sequences. The Spectrum is unique in providing this, and does so by prematurely resetting the rampwave oscillator if it is near the end of its cycle when sampling occurs. Referring back to the LFO circuit diagram, this is achieved by C17 and R99 which couple pulses from the LFO square wave to base 1 of TR7, the uni-junction transistor in the rampwave generator. When the square wave goes low, the reset threshold of TR7 is effectively reduced by about 1 volt, so if the voltage on C15 is above +4V at this instant, the ramp wave is reset early and the sample-and-hold receives the voltage at the start of the next ramp cycle, i.e. -10V. The rampwave generator then runs normally until the next time it fails above +4V on a sample, whereupon it is reset and the sequence is repeated exactly. The time taken for this to occur depends upon the frequency ratio, but since the synchronisation is quite weak, sequences from very short to quite long are easily obtained and very long sequences are terminated when the premature reset condition arises.

The LFO square wave is sent to the envelope generator and shaper separately from the waveform selector switch and modulation routing, where it can be used to gate the envelopes repeatedly.

VCOs and Associated Circuitry

The Voltage Controlled Oscillators (VCOs) are the heart of the analogue synthesiser, and to a great extent determine the overall quality of the instrument. In exponential synthesisers they must be carefully designed to give an accurate and temperature compensated control scale; this normally makes them the most expensive sections and requires complex setting up.

In most small synthesisers the Voltage Controlled Filter is the primary timbre determining section, with variations between designs responsible for the characteristic sounds of different instruments. The VCOs play a lesser part in tone forming, with a limited choice of basic waveforms available to the player. The Spectrum Synthesiser incorporates design techniques never before used in an instrument of this type to provide a very wide range of different timbres from the oscillator section by using the two VCOs in combination.

Circuit (of VCO Section)

Figure 9 shows the circuit diagram of the Voltage Controlled Oscillators. The oscillator control circuitry and the sections that combine the VCO signals by frequency modulation and synchronisation are also included.

Each VCO uses the CEM 3340 IC which is specifically designed for this kind of application, allowing a versatile and precise VCO to be built with great improvements in cost, component count and specification over discrete designs. The CEM 3340 was fully described by Charles Blakey in *IC's for Electromusic*, E&MM March 1981, so except where its usage in this design is unusual, we shall not discuss it in great depth here. The internal diagram is shown in **Figure 10**. The device is an exponential VCO with linear FM, sync and pulse width control inputs. IC15 and IC16 are the basis of VCO 1 and VCO 2 respectively, and pin 15 of each is the exponential control input. This is a virtual earth summing node so each of the required signals for VCO pitch control are routed to this point via a resistor whose value which determines the control relationship (the amount of pitch change for a given voltage change).

With the scale trim presets correctly set, 100k gives the required keyboard control relationship of 1V/Octave.

IC7a inverts the output of the glide circuit, and applies an offset so that the middle ,C' of the keyboard generates a key CV of 0V. This simplifies interfacing with additional equipment. The ,Tune' pot. (RV5) shifts the pitch up to + 2 semitones. R90 limits the current supplied by IC7a but does not affect the voltage under normal conditions. This is required since the CV is momentarily shorted to earth when the other end of the patch lead from JK2, the ,key CV out' interface jack, is plugged into another piece of equipment. The key CV signal is fed to VCO1 and VCO2 via R162 and R163 respectively, which are 100k 1% metal film resistors with a temperature coefficient of better than 100ppm/C. The precision is not important since the scale is trimmed, but the low temperature co-efficient is required to ensure that the control relationship remains constant with varying temperature. IC15 and IC16 are internally compensated for temperature changes, but stability of external control signals is just as important where it affects control scale.

The VCO CV interface socket accepts an external voltage from a device such as a sequencer for additional precise control of the VCOs. The voltage is buffered by IC7b and fed to pin 15 of IC15 by R147, R164 and RV21, and to pin 15 of IC16 by R148, R165 and RV22. Though 100k 1% resistors would give a control scale as precise as that for the keyboard, the external CV must match key CV for scale exactly, so RV21 and RV22 are included. S5, RV15, S7, and R157-161 perform the Modulation routing for the VCOs. S5 selects the source from among the envelope generator, low frequency oscillator, and noise generator, and RV15 controls the depth of modulation from 0 to 5 octaves when controlling pitch. A logarithmic pot. is used to provide fine control at low modulation depths. S7 selects the modulation function from pulse width, where at maximum depth the range is 50% pitch modulation of either VCO or both VCOs simultaneously. The ,Off' position enables a modulation effect to be preset and then switched in when required.

The controller enables the joystick or an exter-

nal device to control either or both oscillator pitches, pulse width, or filter cutoff frequency with variable depth. IC14a amplifies the voltage from the wiper of RV13, the x axis joystick pot. With the controller in/out socket unused, RV14 controls the amount of joystick voltage modulating the function selected by S6. The joystick voltage is available at the controller socket for control of additional equipment, or a foot pedal wired as a variable resistance to earth can be connected to control the selected function. The joystick voltage can be overridden by patching in a voltage from an external low impedance output. A signal from a high-impedance output will be mixed with the joystick voltage.

Each VCO has a range selector switch which transposes the pitch up or down over a total range of six octaves. The voltages for the different ranges are provided by the potential divider composed of R133-R138, RV9-12 and RV19. The 64' position is connected to 0V, and so adds nothing to the basic pitch for each VCO set by RV17 and 18. Successively higher positions of the range switches S3 and S4 add 2.4 volts per position. R145 ensures the correct current/frequency relationship for VCO 1, while VCO 2's control input may be trimmed by RV20 so that the oscillators remain exactly in tune during octave switching. The selected voltages are not sent directly to the VCOs but are buffered by IC13. This prevents the currents taken by R145. R146 and RV20 from affecting the voltages on the divider, which would otherwise cause the position of the range switch of one VCO to effect the pitch of the other. C22 and 23 store the last selected voltage while S53 and S4 which must be break before-make to avoid shorting out sections of the divider, are between switch positions. On many synthesizers, changing the oscillator range causes a spurious pitch to be generated, which often appears as an annoying ,blip' if a note is sounding. C22 and 23 maintain the pitch during the changeover and allow perfect octave switching while playing. R141, R142 are included so that upon either range being changed, the charge currents of C22 and 23 are kept low enough to eliminate any perceptible momentary pitch drop due to drain on the divider.

One special feature of the CEM 3340 is the linear frequency modulation (FM) input, which

allows the frequency of the VCO to be modulated by an audio frequency signal for the creation of new timbres. The current at this input (pin 13) is multiplied by the exponentiated pitch control voltage, so that a constant percentage FM depth is maintained over the range of the oscillator (see 'Advanced Music Synthesis', E&MM March '81). This is ideal for a keyboard-based synthesiser such as the Spectrum, since it allows a FM tone to be set up and played from the keyboard in the same way as a simple waveform. S8 is the FM & Sync function switch. In the 'FM' and 'FM + Sync I' positions, the triangle output of VCO 1, from IC19a, is fed to the linear FM input of VCO 2. C36 removes the DC offset from the triangle wave and is arranged with R190 before S8 and RV28, the FM Depth control, so that the depth can be altered without the charge on C36 changing and causing a brief unwanted frequency shift. The value of R183 has been chosen to give just under +100% frequency modulation depth with RV28 at maximum.

The CEM 3340 is equipped with synchronisation inputs which can be fed with pulses from another VCO to lock the VCOs to the same frequency. The 'hard sync' input accepts positive and negative going pulses which cause the triangle wave to reverse direction during its rising and falling sections respectively. The 'soft sync' input gives access to the potential divider that produces the upper threshold voltage for the triangle wave, and by applying negative pulses to this point the triangle wave is reversed at its upperpeak when it reaches the point at which the input pulses cause the threshold to drop below the level of the waveform. Neither of these methods provide true synchronisation since this relies on the waveform being reset to a fixed point each time, rather than merely reversing its direction. The sync inputs provided do enable the waveform to be synchronised to the frequency of the input pulses, so strictly it is correct to call the effect synchronisation, though 'hard' and 'soft' normally refer to different degrees of the same effect, with hard sync causing unconditional reset of the waveform, and soft sync causing reset if the waveform value at that time is in a particular range, usually above a certain level. The synchronisation facilities provided on the CEM 3340 are unsuitable for the creation of new waveforms, the most useful

property of true sync, so the Spectrum uses additional circuitry to achieve this.

The synchronisation circuit appears in the bottom right hand corner of **Figure 9**. S8b is the pole of the FM & Sync Function switch that controls this circuit. When sync is off (in the 'Off' and 'FM' positions) pin 13 of IC17d is held low blocking the pulse wave from VCO 1, the 'master' oscillator. When sync is selected, the pulse wave is inverted by the NAND gate and the falling edges are differentiated to give 10 μ s wide negative pulses that turn TR15 on. TR16 and TR17 are FETs that provide a low resistance path from C34, the integrator capacitor of IC16, to the potential divider R215, RV29, RV30 when either gate is allowed to go high. Without sync selected, the FETs are held off by R212 via D29 and D30. With S8 in the 'Sync I' or 'FM + Sync I' position, the gate of TR17 is connected to -15V holding it off, but on each sync pulse R214 is allowed to turn on TR16, and C34 discharges to the voltage set by RV30. With Sync II selected TR16 is held off and TR17 discharges C34 to the voltage on the wiper of RV29. Hence, at the end of each cycle of VCO 1, VCO 2's waveform is reset to one of two positions depending on which type of synchronisation is selected.

As can be seen from the internal diagram of the CEM 3340 the voltage on the integrator capacitor at pin 11 is buffered to drive the comparator, triangle wave output, and ramp wave shaping circuit.

The comparator switches the threshold and direction of the triangle waveform when the selected threshold is reached. The buffer produces an offset of about -1.6V and since the comparator refers to the output of the buffer, the voltage on the capacitor ramps between approx +1.6V and +6.6V. RV30 is set to return the buffered waveform to just below 0V, corresponding to about 1.6V on its wiper. This makes sure that the internal comparator is set to its rising state by the waveform crossing the lower threshold. Hence Sync I causes the triangle wave to begin an upward slope from its minimum value at the end of each VCO 1 cycle. Sync II differs in that the triangle wave is set to its midpoint and proceeds in the same direction as before the sync pulse, i.e. the comparator state

is unaffected. This means that slight changes of frequency that bring the VCO 2 triangle wave to a peak before the sync pulse, where the sync pulse previously caught the waveform just before it reached the top, cause discontinuities in the tone and pitch of the sound. This is a feature of the pitch quantising effect of Sync II, where the pitch of VCO 2 jumps from one harmonic to the next as the control voltage to VCO 2 is increased. As a result of the fact that alternate sections of the waveform between sync resets are inverted if the sync occurs on alternate rising and falling slopes, there is an inherent divide by-two so the harmonics generated are really those of the sub-octave of VCO1. **Figure 11** shows some examples of Sync II waveforms, those between the second and third harmonics of the sub-octave of VCO1. Note that as the rate of VCO2 is increased harmonics of the VCO1 fundamental increase in amplitude until the period is suddenly doubled with the introduction of the sub octave component and from there on the harmonics diminish until the triangle wave is restored at a higher frequency.

Sync I produces a smooth change in timbre as VCO2 is swept, since each time sync reset occurs, the cycle starts in the same way. This makes it more useful for timbre modulation, whereas Sync II is best for pitch effects. One of the simplest uses is to generate the effect of a full-wave rectified ramp wave which can be modulated from a complete ramp to a triangle wave from the triangle output. On other synthesisers this is accompanied by a volume change, the triangle wave being half the amplitude of the rampwave, but with synchronisation the level remains fixed over the range, and of course the waveform shape can be swept much further in both directions. As the rate of VCO2 is decreased, a diminishing rampwave is produced giving a new method of amplitude modulation. As it is increased, the band of accentuated harmonics sweeps up the spectrum. **Figure 12** shows some 'Sync I' waveforms obtained from the triangle output with different relationships between the rates of the two VCOs.

So far we have only considered hard synchronisation, where the VCO2 cycle is restarted on every cycle of VCO. This gives the output of VCO2 the same period as that of VCO1, or in some cases of Sync II, double that. If the natural

frequency of VCO2 is adjusted to a multiple of the VCO1 frequency, it will produce its natural waveform though beating effects are eliminated and a slight change of either frequency will introduce components of the VCO1 waveform into VCO2's output revealing the true period. Soft synchronisation causes reset only if VCO2 is past a particular point in its cycle and enables the pitches to be locked in musical intervals corresponding to fractional frequency ratios such as 3:2 (a perfect fifth), 4:3 (a perfect fourth) and 5:4 (a major third).

Conventional discrete rampwave oscillators achieve soft sync by putting pulses on the ramp's upper threshold in the same way as the Spectrum LFO produces its regular S/H waveform. The Spectrum VCOs use a more advanced method which allows precise sync in ratios as low as 500:499 for example, where the VCO2 waveform is reset once every 500 cycles. Such weak synchronisation is heard as a series of clicks rather than an actual change of VCO2's pitch, but intermediate settings can give complex waveforms suitable for imitating many elusive sounds with complex harmonics such as those of engines, creaking doors etc. The synchronisation control in the FM & Sync section varies the depth of Sync I or II from zero (equivalent to no sync selected by the function switch) through increasing depths of soft sync to hard sync at the maximum setting.

The synchronisation control uses the pulse wave facility of the CEM 3340 to inhibit reset until the rampwave of VCO2 has passed a certain point in its cycle. Reference to **Figure 10** shows that the pulse wave is normally derived from the rampwave by comparing it with the voltage at pin 5, the pulse width modulation input. The output at pin 4 is an open NPN emitter, which is high while the ramp waveform is below the PW control voltage. This output is connected to the junction of R210, R211 in the base circuit of TR15 so for the first portion of VCO2's cycle the TR15 is held off and the sync pulses are prevented from resetting the cycle. The proportion of the cycle for which sync reset is inhibited is determined by the setting of RV26, the synchronisation control, which supplies a variable voltage to the PW control input. With the synchronisation control at 0 (>5V at pin 5) no sync reset can occur. At 10 (0V at

pin 5) the PW output at pin 4 has no effect and every sync pulse causes reset (hard sync).

Figure 13 illustrates an example of how soft synchronisation (using Sync II) locks the pitch of the slave VCO (VCO2) in a musical interval with that of the master VCO (VCO1), in this case a fourth (a frequency ratio of 4:3). The sync pulses and waveform at the base of TR15 include positive going pulses (produced by the rising edges of the pulse wave) but these have no effect on circuit operation so are omitted for simplicity. Without the synchronisation operating, the ratio of the VCO frequencies would be 39:30, a flat fourth. The dotted line shown against the VCO2 ramp wave represents the level at the PW control input of IC15, pin 5, and corresponds to a setting of 3 on the synchronisation control. While the ramp is below this level the base of TR15 is held high, blocking the sync pulses. The phase of the higher frequency VCO2 waveforms advances until a sync pulse coincides with the portion of the ramp above the dotted line, and the VCO2 waveform is reset to zero (point 'A'). This brings the ramps into phase, and until the sync pulses again successful (point 'C'), VCO2 runs freely. Though the fourth above VCO1's pitch is heard clearly in the output of VCO2, the actual pitch of VCO2 is two octaves below this, at the lowest common denominator of the two frequencies. In practice this can be eliminated by tuning VCO2 up until a near perfect triangle or ramp is produced with the sync pulses just catching the end of each fourth cycle, but since the extra components form a third note at the root of the chord it could be left in to produce richer sounds. When using soft synchronisation, the PW output of IC16 turns TR15 off as soon as the reset takes the ramp waveform below the voltage on the wiper of the sync control (the dotted line). This would cause the new cycle to begin at some point above 0V (or with Sync II above 2.5V) depending on the point it was at before the sync pulse. C38 is included to keep the FET on for a short time after the reset turns TR15 off, ensuring that C34 discharges to the voltage on the potential divider.

The pulse wave output of VCO1 is variable from 0 to 50%, by the Pulse Width control and from 0 to 100% with modulation. IC14b sums the voltages from the PW control, modulation

routing and controller. The output is low-pass filtered by R180, C28 before being fed to the PW control input of IC15. This is to prevent stray feedback from the pulse output causing a fast burst of pulses on the falling edge which would confuse the sub-octave generator. C29 performs the same function on IC16, preventing spurious synchronisation pulses. The pulse output at pin 4 of IC15 is pulled down by R187. The waveform is sharpened up by IC17a, a Schmitt NAND gate connected as an inverter, and used to clock the flip-flop IC18a. This produces a square wave of half the frequency, which is mixed with the pulse wave to give the sub-octave waveform.

The flip-flop input would oscillate with the slow edges of the raw pulse output of IC15, so the Schmitt gate is necessary for proper division. The pulse output of IC15 is the source for the synchronisation circuit, so the sync effect can be turned on and off by modulating the PW through 0%. Hence, for example, the joystick can be used to bring in parallel harmonies or the free phase sound of unison oscillators could be introduced by the envelope generator as a note decays.

The VCO2 pulse is derived from the rampwave by IC17b. RV27 allows its width to be set. VCO2's sub octave waveform is generated by IC18b. The rampwave outputs of IC15 and IC16 are used directly and the triangle wave outputs are buffered by IC19a and b respectively. The half wave rectified ramp waveforms are produced by mixing the triangle and rampwaves in equal proportions. S9 and S10 are the waveform selector switches for the two oscillators, and connect to a virtual earth summing mode in the VCF circuit. R195-208 are chosen to give equal peak amplitudes for the different wave forms.

The two sub octave square waves are NANDed to provide the drive to the tuning LED. When the waveforms are out-of-phase, the output is high and the LED off. Advancing phase difference due to slightly different frequencies produces a pulse wave that varies from 100 to 50% width, displaying the beats as fluctuating LED brightness.

Ring Modulator and Noise

The ring modulator (**Figure 15**) is based around IC20 and processes the pulse wave of VCO1 and the triangle wave of VCO2 to produce complex non-harmonic sounds. It functions in a similar way to the rampwave shaper of the Spectrum LFO by inverting the triangle wave about its midpoint when the pulse wave is high, and leaving it unchanged when low. This constitutes four quadrant multiplication of the value of the triangle wave by the value of the pulse wave (-1 or +1). When the pulse output is low TR12 is off and the triangle wave is inverted with a gain of 2 by IC20a. The output is mixed with the original triangle wave of half the amplitude and opposite phase by IC20b. With the pulse output high the collector of TR12 is at -15V and the output of IC20a is positive. This reverse biases D32, and no signal reaches IC20b via R221. The original triangle wave is inverted by IC20b and shifted by the current through R220. The output of IC20b is the required product.

The noise generator is quite conventional, using the thermal noise of a semiconductor junction as a source. TR14 amplifies the noise on the emitter of TR13 to about 4mV p-p, which is boosted to +2.5V by IC21. RV31 mixes the noise and RM signals, which are then fed to IC22, a transconductance amplifier which acts as a VCA. S11b selects the appropriate modulation source, which is conditioned by IC23. The LFO signals are symmetrical about 0V, whilst +EG swings from 0V to +5V and -EG goes from 0V to -5V. In order that all these signals have the same effect, therefore, an offset is selected by S11a and added to the modulation so that pin 6 of IC23 always swings between 0V (maximum gain) and about -1.4 volts. The CA3080 is really a current controlled amplifier, and so R237 converts this voltage swing into a control current. Since IC23 cannot completely cut this current off, R238 and diodes D33-D35 are included to ensure that the amplifier is truly off at the maximum negative control voltage.

The Filter

The heart of the filter is the CEM 3320 IC from Curtis Electromusic Specialities. Designed especially for use in voltage controlled filters, this IC contains four identical filter elements controlled by a temperature compensated ex-

ponential converter. Each element contains a transconductance type amplifier plus a buffer amplifier to avoid loading of the TCA's output. Depending on how the circuit is connected, either low pass or high pass filter sections may be created as in **Figure 16**; the three modes of the Spectrum's filter are formed by different combinations of these.

The low pass response is obtained with four low pass filter sections; since each section has a roll off of -6dB/octave, the overall filter slope is -24dB/octave. The band pass response has two low pass sections, preceded by two high pass sections so that only signals in a narrow range of frequencies are allowed through. The low band pass position, as you might expect, is a mixture of the preceding two configurations and consists of only one high pass section followed by three low pass stages. Switch S12 rearranges the signal paths and biasing around the IC to allow the three different configurations to be achieved.

The final part of the CEM 3320 is a fifth transconductance type amplifier with its own control input. This is used in a feedback loop around the filter to control the 'Q' or resonance; this causes frequencies around the filter's cut off or centre frequency (depending on mode) to be accentuated. RV36 is the resonance control, and its range has been set such that the band pass filter will oscillate at the maximum setting of this control to give a sine wave whose frequency can be controlled by the filter's cut off control voltage IC24b is a four input mixer, accepting signals from the VCOs, the noise/RM VCA and the external input socket JK7. R242 is included to combat stray capacitance effects caused by the long leads to the VCO waveform selectors.

The CEM 3320 does not have a summing control input as the oscillators do, and so IC26 performs this function. As well as modulation inputs selected by S13, the key CV is fed in via the 'keyboard follow' control RV40. When this control is at maximum, the filter's cut off frequency has the same 1V/octave law as the oscillators, and hence will track the keyboard so that the notes have a constant timbre. On most acoustic instruments, however, the upper notes have less harmonics than the lower ones, and if the key CV is attenuated by RV40 this

effect may be obtained on the Spectrum. RV37 is included to allow setting up of the 1V/octave law, and if required, may be set to give the reverse of the above effect. In this case, setting the 'keyboard follow' control to 10 will cause higher notes to have more harmonics, and true keyboard following will occur at some lower setting.

Since the filter control characteristic is not as critical as that of the oscillators, low temperature coefficient components are not really necessary in this part of the circuit. One exception to this could be where the filter is made to oscillate to act as a third VCO; in this case, R249, 251, 256, 257, 260, 264, 267, 268 and 270 should be 1% metal film types, and RV37 should be a multiturn cermet component for precise setting up.

Voltage Controlled Amplifier and Pan

The last board in the synthesiser, but by no means the least, contains two VCAs and two envelope generators (EGs); the overall circuit is given in **Figure 17**. Both VCAs are contained in IC28, a CEM 3330.

Some samples of this IC oscillate as they get warm, and so the dissipation is minimised by running IC28 from +10 volts derived from D41. This not only cures the instability problem, but helps to reduce noise generated in the VCAs.

IC28a performs the envelope shaping function, and is fed with the envelope signal via R274 since this IC works with current inputs and outputs rather than voltages. R273 performs the same function for the audio input, whilst IC29b converts the output current back into a voltage.

Panning and modulation are performed by IC28b, which works in an identical manner to IC28a; audio and control inputs are via R287 and R288 respectively, and output conversion is done by IC29c. When the FUNCTION switch S14 is in one of the MOD positions, both stereo outputs are connected to the second VCA, which then simply modulates the amplitude of the envelope shaper output according to the LFO waveform. IC30 amplifies and level shifts the selected waveforms so that the top

end of RV42 always swings between 0 and +12V. Instead of going to 0V, which would cause IC28b to cut off the signal when the DEPTH control was at minimum, the other end of RV42 goes to a reference voltage generated by R292, 293, RV44 and buffered by IC27a.

In the pan mode, only one stereo output comes from the second VCA; the other is fed from the input of this VCA, the envelope shaper's output, via IC29d which subtracts the first channel's signal. This means that as one channel's output becomes louder, the other becomes softer and vice versa, in such a way that the total output is constant; so the volume is unaffected, but panning is achieved. The gain of the various circuits is arranged so that when IC28b is at around unity gain (100uA into pin 12) the output of the two channels is equal; i.e. 3V peak to peak with one VCO on, no filtering and RV45 at maximum. With full modulation, therefore, each output swings between zero and twice this figure.

IC29a combines half of each of the stereo outputs to give a mono signal of the same amplitude, which is affected by modulation but not by panning.

While the Spectrum's output is normally in the region of 3V pk pk, 1V rms, factors such as modulation, resonance on the filter etc. can increase this to a maximum of 25V pk-pk. If required, the output may be attenuated by inserting resistors in series with the clockwise tags of RV45a and b. The output may be fed into any impedance greater than 25k; below about 10k, loss of bass may become apparent.

Envelope Generators

Once again, Curtis Electromusic come to the rescue and each envelope generator is built with a CEM 3310. Both circuits are identical in most respects, except that IC32 has an inverter on its output to provide EG+ and EG- signals, plus the circuitry for achieving key repeat.

R309 and 311, C59 and 61 set the speed range of each generator, and have been chosen to facilitate setting very fast attack times whilst allowing slow decay and release. These com-

ponents affect all three times equally, and if desired, R309 and 311 may be increased to 'slow down' the envelope times.

Sustain level is controlled by RV48 and RV53. It is important that the sustain control voltage at pin 9 of each IC should not exceed the peak level attained during the attack phase; since this level is available on pin 3, the sustain pots are simply run from this voltage. If external modulation of sustain level was required a more elaborate level sensing circuit would be necessary (as described in the Curtis data sheet).

Pin 4 is the gate input, and the trigger signal for pin 5 on each IC is derived by C57. In addition, IC33a and TR15 are brought into play on the 'repeat' and 'key repeat' functions; IC33a detects when the envelope out put has reached the sustain level (i.e.the attack and decay phases are finished) and TR15 briefly pulls the trigger inputs high to restart both envelopes. IC27b detects the signal at pin 16 of IC32, and lights D38 to indicate when this IC is in its attack phase.

Construction

The Spectrum Synthesiser is not a beginner's project; it needs careful assembly and alignment if it is to work reliably and accurately. Before starting, then, read through the text, make sure you have some understanding of how the circuits function in case a fault develops; make sure you have the necessary tools and assembly skills and finally, make sure you have (or can borrow) the requisite setting-up instruments.

All the Spectrum's circuits can be built on their own for use in other 1 volt/octave synthesiser systems; and in many cases, the Spectrum may be expanded by adding more controls or by building more circuits. Modification and expansion details could double the size of the project, however, and so will not be dealt with here.

Components

It goes without saying that for maximum re-

liability, only good quality components should be used in the Spectrum; the more parts there are in a project, the higher the probability that one will be faulty. In some cases, a particular component is necessary to ensure correct operation of a circuit, or to combat drift which would make constant re-alignment necessary.

In general, none of the ICs should be substituted, especially where FET or MOSFET input op-amps are specified. Where 741 or 1458 types are used, however, things are less critical and any internally compensated op-amp with similar (or better) specs may be used. Transistors and diodes are again mostly non-critical; as long as the transistors have reasonable gain and low leakage, any type capable of withstanding at least 30 volts should be suitable. The FETs used in the sample and hold and sync circuits should be selected with important parameter here.

Nearly all the non electrolytic capacitors are specified as polycarbonate (or, on the VCOs, monolithic ceramic) for reasons of space rather than specification. The most critical areas here are 1) C11 and C13 on the keyboard controller, which must be low leakage; if the open ended type of polycarbonate capacitor is used, it is a good idea to coat them with proper insulating varnish prior to assembly 2) The stability of C31 and C34 will affect the tuning stability of the whole instrument; the 1% polystyrene types specified should be used. 3) C43, C44, C45 and C46 in the filter should be reasonably well matched, but the ordinary 5%, polystyrene components are satisfactory here; do not use ceramics.

Sockets are specified for all ICs; whereas these are not compulsory, they are strongly advised to simplify fault finding (and to reduce the likelihood of fault finding becoming necessary!).

Metal film resistors are specified in several places because of their better stability and temperature coefficient; these need not be 1%, tolerance but usually are. Cermet presets are specified in some positions for the same reasons, and the most critical adjustments use multiturn components. Some of the carbon film resistors are listed as 1/2W types, but only because the range of values is greater; if available in the 'odd' (E24) values, 1/3W types may be used throughout.

IC11 on the LFO board (CA3140) is only available in the metal can package (suffix T) from many suppliers, including Maplin. The DIL plastic version (suffix E) is preferable if you can get it, since it allows the use of a socket.

General Assembly Notes

All the Spectrum's circuitry is built on printed circuit boards, assembly of which should follow the normal procedures. It is best to start with the small components, such as wire links and resistors, and work up to the larger ones to avoid the board becoming too 'lumpy' and difficult to work on in the early stages of construction. Semiconductors should be left till last, with ICs being plugged in last of all; always check the orientation of all the polarised components at least twice before applying power. Diodes, transistors, ICs and electrolytic capacitors must all be the right way round.

When fitting components with their values printed on them, it helps subsequent checking if the component is inserted so that the printing is on top, or at least easily viewable.

Take care when there are 1% resistors on a board with the same value as ordinary resistors; sort out the close tolerance components and fit them first, to avoid errors. Otherwise, you may find you've used up all your 1% resistors in non critical locations!

Keyboard Construction

Use the printed circuit board as a template to mark the fixing holes on the underside of the keyboard chassis.

Mark them such that the edge of the board holding the bars will be about 5mm from the plungers and then drill for 6BA clearance. Fit the 48 divider resistors on the component side of the board along with the 12 veropins and solder in place. Cut the palladium bars to length and fit them to the track side using small loops of wire passed over the bar, through the mounting holes and twisted on the component side. Make sure each bar is well seated before soldering at each loop position on both sides.

The gate bar should lie flat on the PCB, whilst the S/H bar should be spaced away from the surface slightly by wrapping the mounting wire round the bar before soldering. This gives one wire diameter under the bar, and ensures more reliable contact.

Cut each plunger to length, leaving the nearest slot to the key end for the contact. Tin 5mm of both ends of the contact springs and fit each one by passing the thin end through the detached plunger and soldering it to the pad on the PCB. If you've marked the PCB mounting holes correctly then for proper operation the end of the spring should be about 2mm from the far edge of the pad. The positioning of the PCB and the springs on the PCB is not critical as long as when the PCB is mounted and the plungers clipped on, the springs are under slight tension to ensure positive contact. Mount the PCB to the chassis using 6BA bolts, 1/2" spacers and nuts, and washers to separate them further. The keys opposite the mounting positions will have to be temporarily removed to fit the bolts, and this should be done before drilling if a hand-held drill is used, to avoid the possibility of damage to the keys. Again, the spacing is not critical so long as all the contacts normally clear both bars and make contact with both when their keys are depressed. A 1/2" spacer and one nut were found to be about right, though washers could be used if a high or low action to the keys is preferred. Connect the two halves of the board together using short wire links across the Veropin pairs. This completes the keyboard construction.

The assembly can be tested on its own by connecting a multimeter set on the low resistance range across pins 1 and 3. Depressing the bottom key should give zero resistance, and the top key about 2.4k. Check that all the other keys give intermediate readings and repeat for the other bar with the meter across pins 1 and 4.

Panel Wiring

Figure 25 identifies the panel mounted controls and their connections, viewed from behind. Table 1 gives the point to point wiring details; terminals on the controls are as shown

in **Figure 25**, while connections to the PCB pins are numbered on the appropriate board drawings. The prototype used Minicon connectors on the PCB pins for ease of removal of the circuit boards, but ordinary Veropins are cheaper and more rugged.

There is quite a lot of wiring between the front panel components which does not go to any board, and it is a good idea to do this first so that wires are not melted by trying to get a soldering iron in to the middle of a mass of 'spaghetti'. When wiring to the boards, groups of wires often go together to one switch or pot, and it keeps things neat if these groups are wired using ribbon cable.

To keep interaction low, it is best not to try to make all the wires into one gigantic cableform, but to keep the wiring for each front panel 'box' separate from its neighbours. Remember to use screened cable where this is called for.

The power supply leads should not be 'chained' from one board to the next; instead each board must have its own separate leads for +15V, -15V and ground all going back to the tag strip mounted near the PSU. Do not connect the tag strip to the power supply board itself just yet, as this will facilitate checking the circuitry and setting up.

Setting Up

The power supply should be set up first; none of the other circuits will work without it, of course, and various voltages are derived from the + and - 15 volt rails. Adjust the output voltages without the rest of the circuitry connected to begin with; RV1 sets the + 15V output, RV2 the -15V. Use the most accurate voltmeter you can get hold of; a digital multimeter would be best, and an oscilloscope is likely to be more accurate than a cheap mechanical meter. On the prototype, the entire synthesiser consumed around 115mA on the +15V line, and 130mA on the -15V line. If you have a dual bench power supply, you may like to check the consumption of the rest of the synthesiser before connecting it to the PSU. If not, the Spectrum's supply has current limiting to protect it from faults, but it is still worth while to insert a currentmeter in

each supply line in turn to check for excessive current drain. Once you are sure there is nothing drastically wrong, the power supply can be connected up to the rest of the circuitry. Connect the output socket(s) to an amplifier, and you should be able to persuade the synthesiser to make some sort of a noise, although it will probably be horribly out of tune. After allowing everything to warm up for as long as possible - 1 hour say - the rest of the circuits can be set up in the following order.

Keyboard Controller

Set the TUNE control to midpoint, and the GLIDE control to zero. Monitor the key CV output from the VCO (pin 99) with the most accurate voltmeter at your disposal. If the Spectrum is to be used with other equipment already calibrated at 1 volt per octave, a digital meter will be essential here; otherwise, this measurement is less critical.

Press middle C on the keyboard. The key CV should be roughly 0 volts; make a note of what it actually is. Now press the next C up from middle C, which should produce a key CV 1 volt above that for middle C. If it is more than this, turn RV3 clockwise and vice versa. The middle C key CV will now have changed, so repeat this procedure as many times as necessary to obtain the correct 1 volt per octave change.

VCO Octaves

The VCOs are the heart of the synthesiser, and time and trouble taken in setting them up carefully will be directly reflected in the final performance of the instrument. Some way of monitoring the oscillators' frequency and comparing it with a reference will be necessary. The ideal solution is a digital frequency meter, which combines monitor and reference in one. Alternatively, the reference can be a signal generator, which must be stable; or a known in tune musical instrument, preferably a divider type organ since it can sustain indefinitely and the octaves will be guaranteed perfect. Monitoring can be performed simply by listening to the synthesiser and reference together, or by feeding both into a dual beam oscilloscope; if the scope is

triggered off one input, the other trace will not be stable until the two frequencies are a simple multiple of each other. Using 'spiky' waveforms makes it easier to see when the two are in tune and not at some interval apart. If you have a single beam scope, but with an external X input, then Lissajous figures could be used instead. Constructors with exceptional hearing may like to set up the octaves by ear; but be warned, the Spectrum has a range of nine octaves, and a small tuning error can add up to a big one over the whole span of the instrument.

Whichever method you are using, set controller, modulation, sync and VCO2 to 'off'; set RV55 and RV56 fully clockwise, and the other presets to their mid position. If you are listening to the synthesiser's output, then set the filter to 'LP' mode and its frequency at maximum; switch the gate mode to 'hold' and the envelope shaper sustain to maximum. If monitoring with a scope or frequency counter, a good square wave can be obtained from the junction of R196 and R197 on the VCO board; set VCO1 pulse width to 50%.

No matter how you monitor the Spectrum's frequency, do not rely on the keyboard controller to keep a note you have pressed stable over several minutes; keep 'topping up' the sample and hold by occasionally repressing the key you are tuning, or leakage will eventually make the note go sharp.

Now go to the paragraph relevant to the equipment you have available.

1) With a frequency counter.

Set VCO1's range to 8', and sound the first A up the keyboard; note its frequency, which will eventually be 220Hz; don't worry if it isn't.

Press the second A up, and its frequency should be an octave above the first; i.e. exactly twice that of the first.

If it is flat, i.e. lower than it should be, turn RV23 anticlockwise and vice versa.

Now go back to the bottom A, which will also have changed, and repeat the process as many times as is necessary to obtain an exact dou-

bling of frequency when going from the first A to the second.

The upper frequency range needs to be set separately; set VCO1's range to 2', and once again play two notes an octave apart. This time, leave RV23 strictly alone and adjust RV55 to give a doubling in frequency. The VCO will always be flat, so turn RV55 anticlockwise to correct this; this adjustment is not as critical as the basic low frequency one.

2) With an organ or other reference instrument.

Set VCO1's range to 8' and sound the first A up from the bottom of the key board. Find the same A on the reference instrument, and tune the synthesiser to it with RV17.

Play the A an octave up on both instruments and determine whether the VCO is sharp or flat. Turn RV23 clockwise if it is sharp and vice versa.

The bottom A will now be out of tune again, so repeat this procedure until the two instruments have the same octave interval.

Now set VCO1's range to 2' and repeat. This time, leave RV23 strictly alone and adjust RV55. The VCO will always be flat, and RV55 should be turned anticlockwise; this is purely a trimming adjustment, and is not as critical as RV23.

3) With a signal generator.

Set the signal generator to around 220Hz; press the first A up the keyboard with VCO1 set to the 8' range, and tune the signal generator to the synthesiser.

Without altering the signal generator, play the second A, an octave above the first. Now use the keyboard TUNE control to obtain either a stable oscilloscope display, or no 'beating' between the two sound sources. Now return the TUNE control to mid point, and adjust RV23 to give the same effect; you will need to turn RV23 the opposite way. For example, if the second A was flat, you would have had to turn TUNE clockwise, and RV23 should be turned anticlockwise.

Now go back to the first A, retune the signal generator, and repeat the process until no adjustment of the TUNE control is necessary when playing the second A.

Finally, repeat the whole procedure but with VCO1 set on the 2' range; leave RV23 alone, and trim RV55 to give correct octaves at the higher frequency. Since the VCO will always be flat, the TUNE control can be left and RV55 turned anticlockwise.

VCO2

No references are required for the rest of the tuning up; VCO2 is best adjusted with reference to VCO1 to ensure the two oscillators track exactly.

Listen to VCO1 and VCO2 together, both on the 8' range and with VCO2's TUNE control central. Press any note low on the keyboard, and tune the VCOs together with RV18. Now press a high note and, by switching VCO1 and VCO2 off alternately, determine whether VCO2 is sharp or flat in relation to VCO1. If it is flat, turn RV24 anticlockwise and vice versa.

Repeat the above paragraph until the oscillators stay in tune over the whole span of the keyboard, but without changing ranges at this point.

Now switch both VCOs to 2' range, and repeat the procedure, tuning RV56. VCO2 will always be flat to begin with, and so RV56 will need to be turned anticlockwise.

VCO Range Switches

Set both VCOs to the 64' range, play a high note, and tune the oscillators together using RV17 or 18. Switch VCO1 to 32' and adjust RV19 for minimum beating; then switch VCO2 to 32' and tune the VCOs together again with RV20. Switch VCO1 to 16' and adjust RV12, then switch VCO2 to 16' and both oscillators should be in tune; if not, trim RV20 very slightly. Switch VCO1 to 8' and adjust RV11; adjust RV10 with VCO1 on 4' and VCO2 on 8', and finally switch VCO1 to 2' and VCO2 to 4' and adjust RV9.

The oscillators should now remain in tune with each other over the whole range of the keyboard and range switches; in practice, slight anomalies in the control characteristics will prevent perfection being achieved, but only the slightest touch of VCO2 TUNE should be necessary to correct any mistracking.

VCOs - Final Adjustments

Once the oscillators are tracking satisfactorily, set VCO2 TUNE and the keyboard TUNE to mid position, and tune the second A up the keyboard to middle A, or 440Hz. RV17 tunes VCO1, and RV18 tunes VCO2. If the Spectrum is to be used with another instrument which cannot be tuned, you may prefer to tune up to that instead.

RV27 may be used to set the width of VCO2's pulse output, or simply left midway. RV29 should be set to give 3.85 volts on its wiper, and RV30 to give 1.6 volts on its wiper.

The final VCO adjustment is to centre the horizontal joystick movement. Loosen RV13's clamp screw, shown in **Figure 25**. Set controller FUNCTION to VCO1, and DEPTH to 10, whereupon VCO1 will probably go wildly out of tune. Hold the joystick lever and RV13's trim tab central, and rotate the body of RV13 to bring VCO1 back into tune; then do up the clamp screw. Once the joystick is mounted, and after transporting the synthesiser, adjust the trim tab so that when the controller DEPTH control is rotated back and forth, no perceptible pitch change takes place.

LFO

RV8 is the only adjustment on the LFO. Set oscillator modulation as follows: SOURCE to LFO MAN, DEPTH to 10 and FUNCTION to VCO 1 + 2. Modulation of the VCOs will now be apparent; with the joystick lever and RV7's trim tab central, adjust RV8 until there is no modulation breakthrough.

Noise and RM VCA

Switch off both VCOs, and turn up the NOISE AND RM LEVEL. Select square wave output

from the LFO, and turn noise & RM modulation SOURCE to +LFO. Turn RV35 fully anticlockwise, so that noise comes through loudly whilst the LFO LED is off, and quietly when it is on; a fairly slow LFO rate is advisable.

Now turn RV35 clockwise until the noise is just cut off during the LED on periods. If any clicking or thumping is apparent as the LFO switches, adjust RV33 to get rid of it. Now turn the SOURCE switch to +EG, turn the envelope generator SUSTAIN to zero, and turn RV34 fully anticlockwise. Some noise will now be heard on the Spectrum's output; turn RV34 clockwise until it just disappears. Turn down the noise LEVEL, and return SUSTAIN to 10. Filter RV37 adjusts the filter's volts per octave characteristic, which is not nearly as critical (or difficult) as the adjustment of the VCOs, and may be done most simply by ear. Set the filter controls as follows: RESPONSE to BP, FREQUENCY about midway KEYBOARD FOLLOW to 10, RESONANCE to 10 and DEPTH to 0. The filter should oscillate with a pure tone which can be played from the keyboard; to avoid confusion, make sure both VCOs and the noise & RM are off. Set RV37 midway, and play a scale on the keyboard; e.g. C major, all the white notes between one C and the next. If the scale sounds 'compressed' - as if it should go on longer to reach the proper note - turn RV37 clockwise, and vice versa.

Altering RV37 will also alter the tuning of the whole scale, but carry on playing and adjusting until the scale 'sounds right'; like the doh, re, mi . . . etc you learnt in school. Finally turn the resonance down ready for the final setting up.

VCA and Pan

With the synthesiser still set to give no sound, turn the GATE MODE switch to LFO, set the envelope shaper SUSTAIN to 10 and ATTACK and RELEASE to 0. Turn up the LEVEL control, and there will be a 'thump' each time the LFO switches (along with some background noise). Adjust RV41 to minimise this thump.

Now switch the GATE MODE back to HOLD, and select either LFO MOD on the OUTPUT FUNCTION selector; the LFO should still be giving a square wave. Turn up the DEPTH control, and the thumping will return, but sharper this

time - more of a clicking sound. Adjust RV43 to get rid of this as far as possible. If necessary, keep turning up the amplifier's volume as these adjustments progress to keep the clicking audible.

Turn DEPTH back to minimum, select any 'pan' position on the FUNCTION switch, and monitor the stereo outputs with a dualbeam 'scope or well balanced amplifier and headphones. Turn on one of the VCOs, and adjust RV44 to give equal outputs from each channel.

Finally, adjust RV50 to give -0.24 volts on pin 156 - or the clockwise tag of any ATTACK, DECAY or RELEASE pot - with respect to 0V.

This completes the construction of the Spectrum Synthesiser. Read 'Electronics & Music Maker' magazine for articles on playing technique and details of a demonstration cassette.

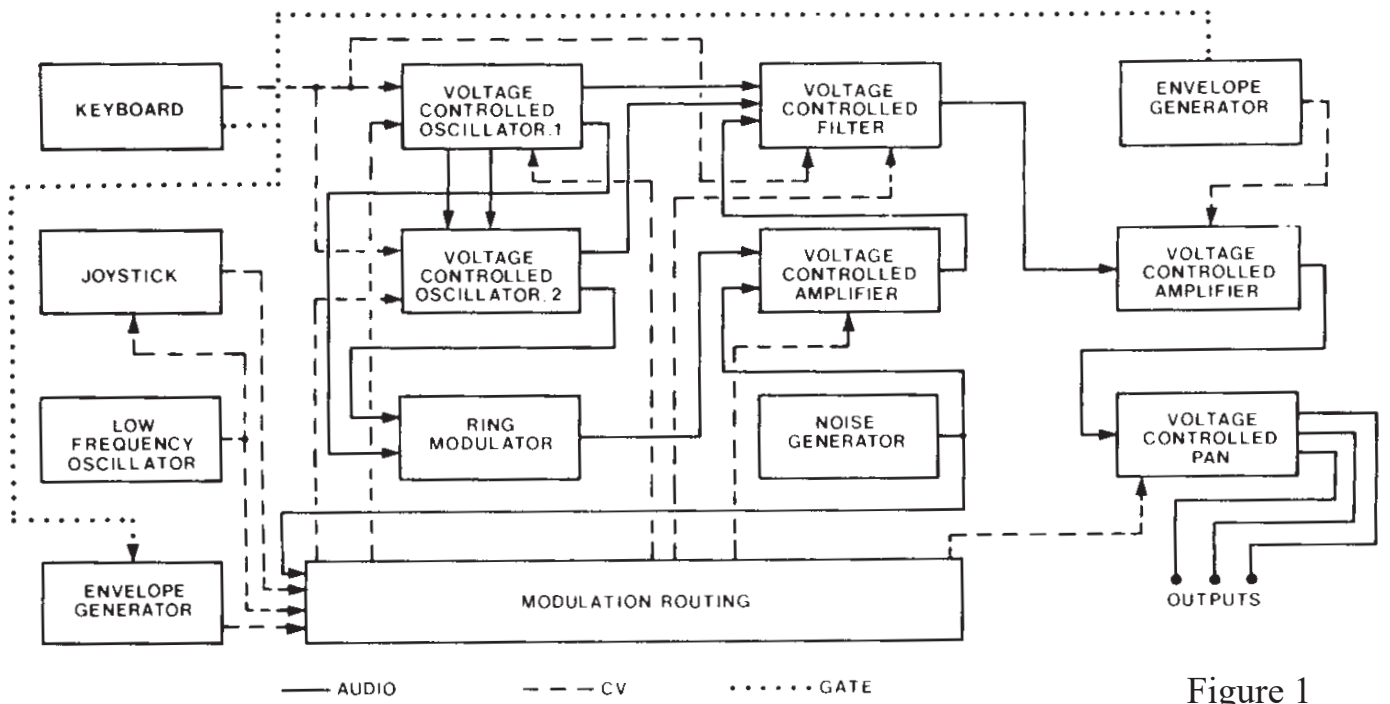

Figure 1

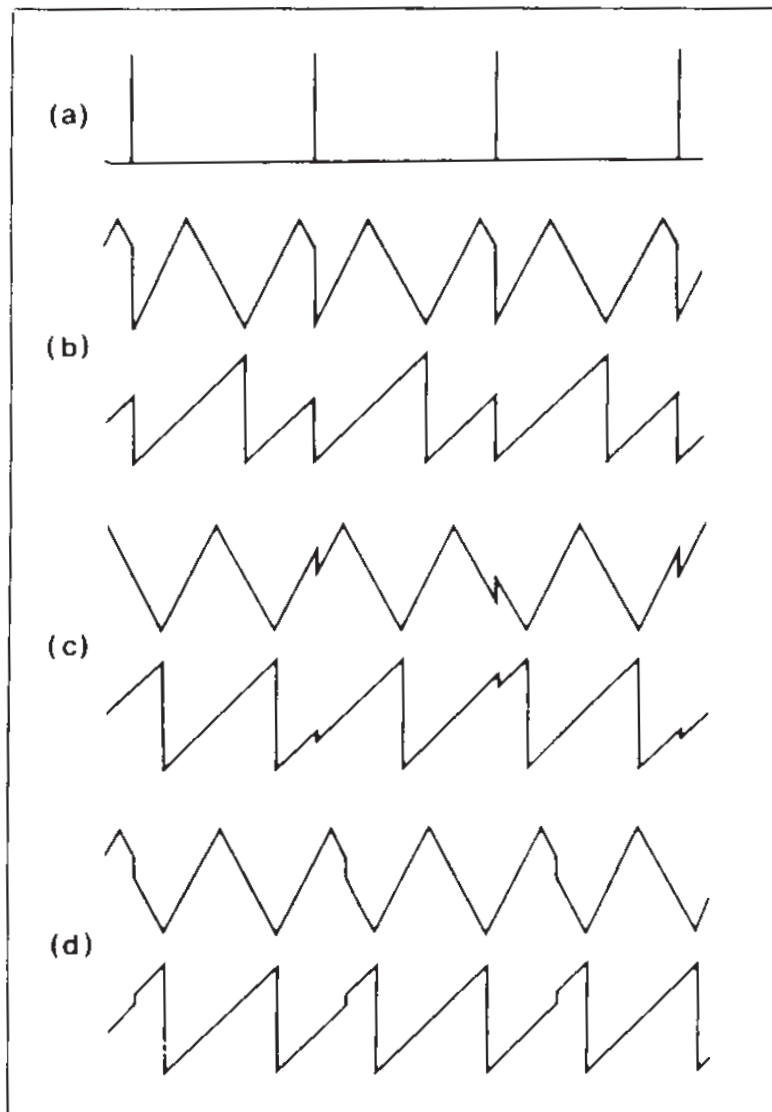

Figure 2. Sync. waveforms. (a) Sync. pulses. (b) Sync. I. (c) Sync. II. (d) Sync. II with decreased VCO1 frequency.

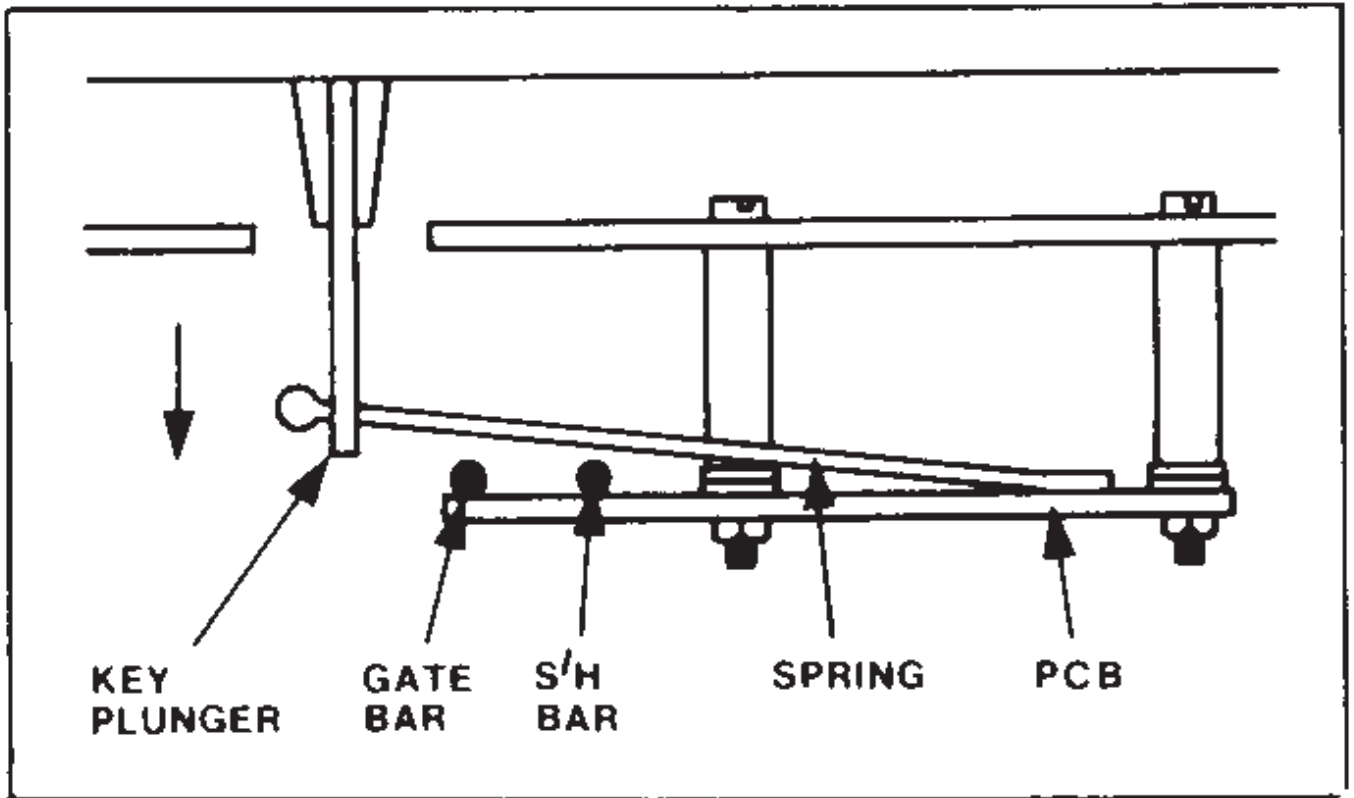

Figure 3. Key contact construction.

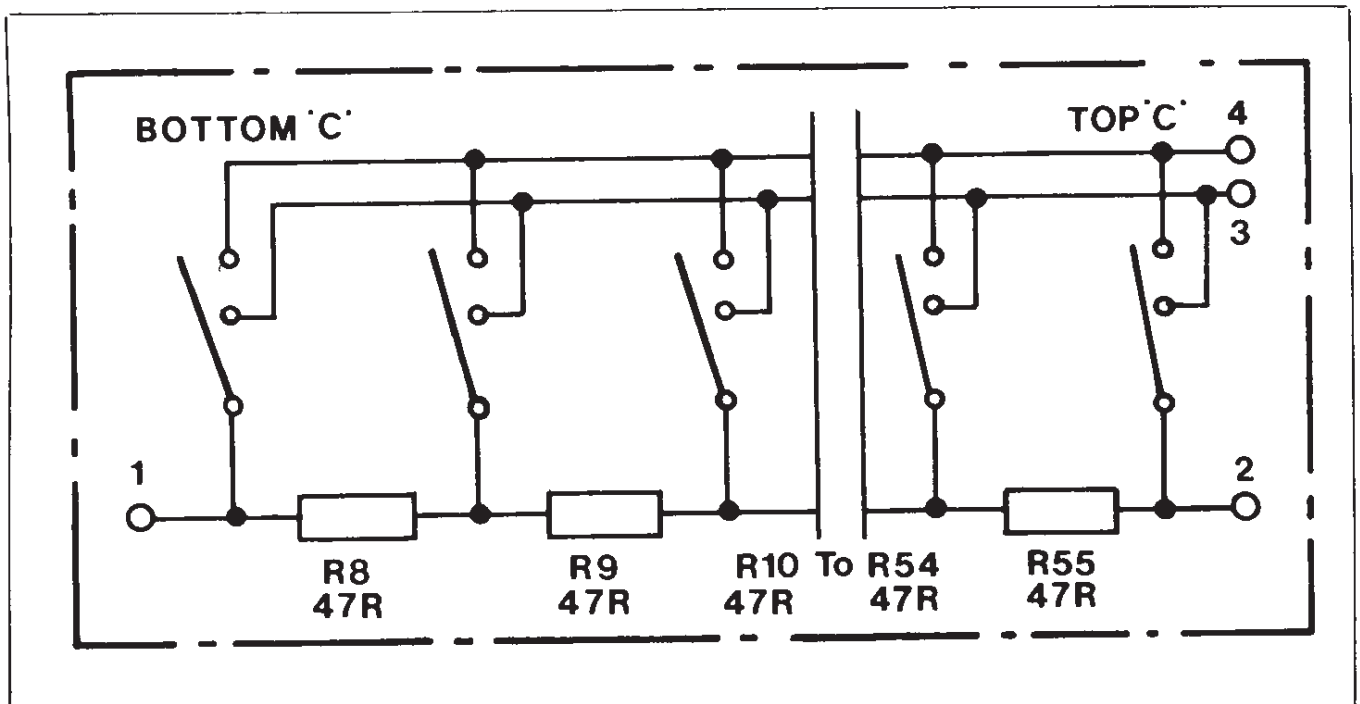

Figure 4. Circuit of key contact assembly.

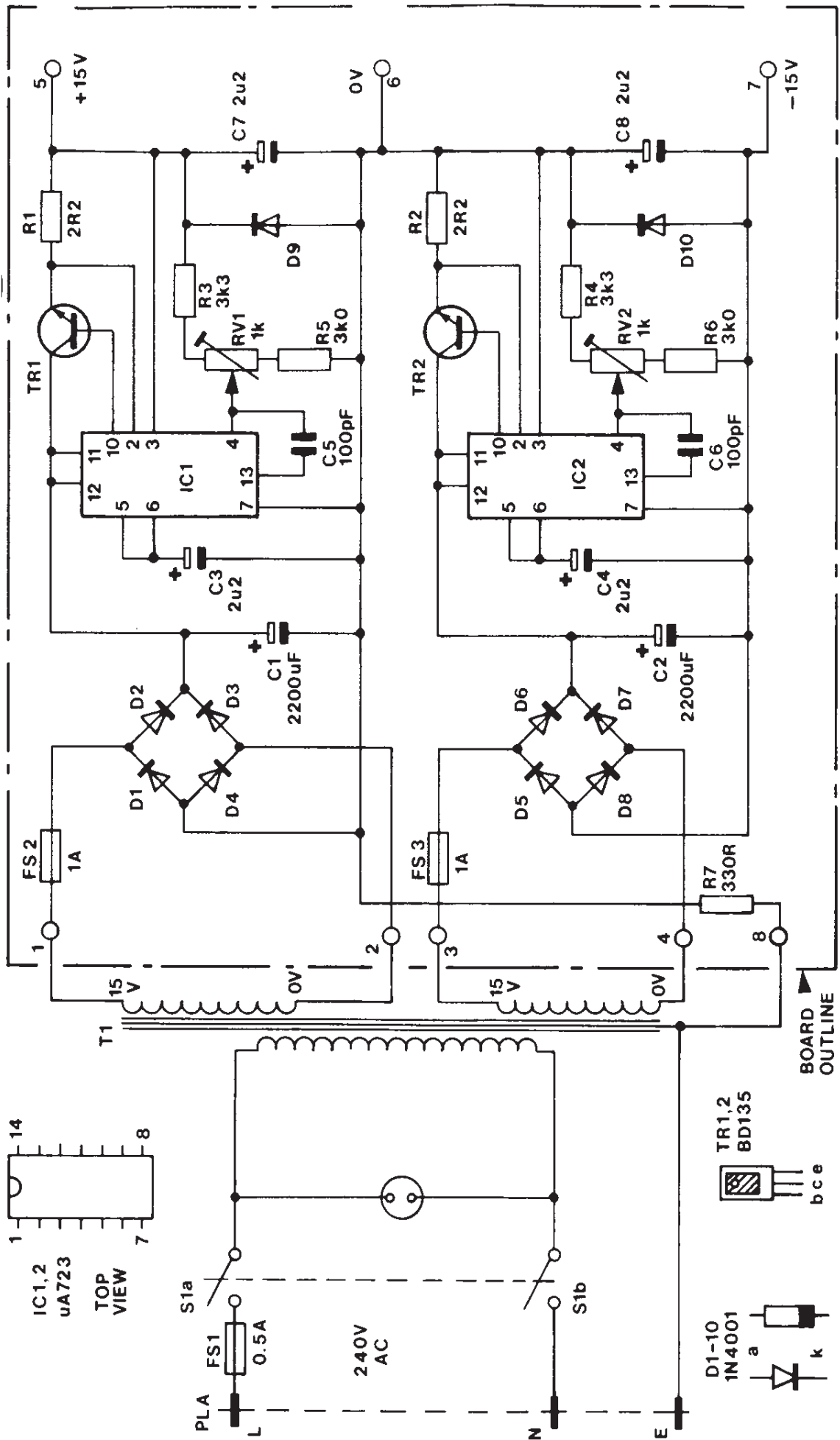

Figure 5. Power supply circuit.

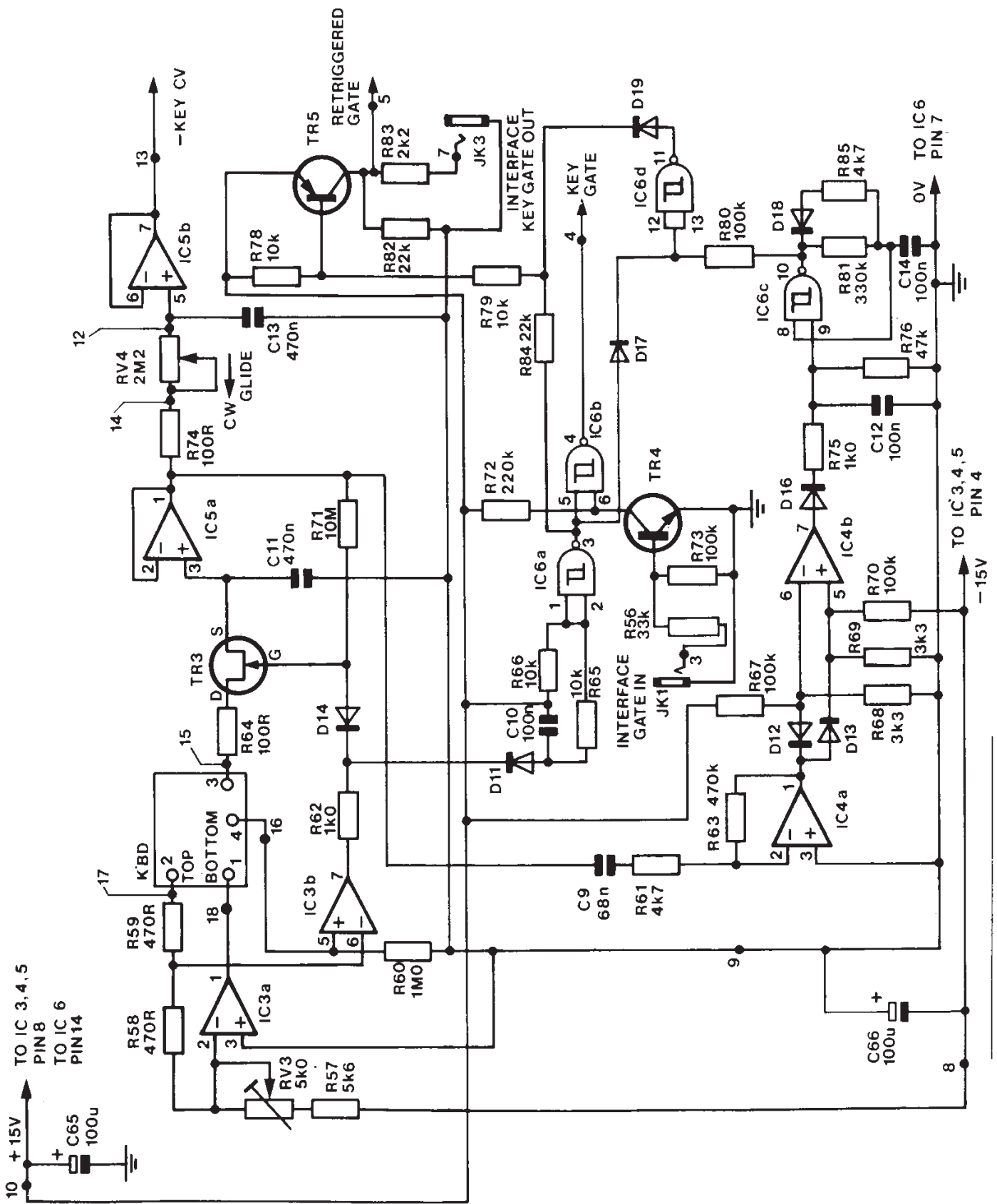

Figure 6. Keyboard controller circuit.

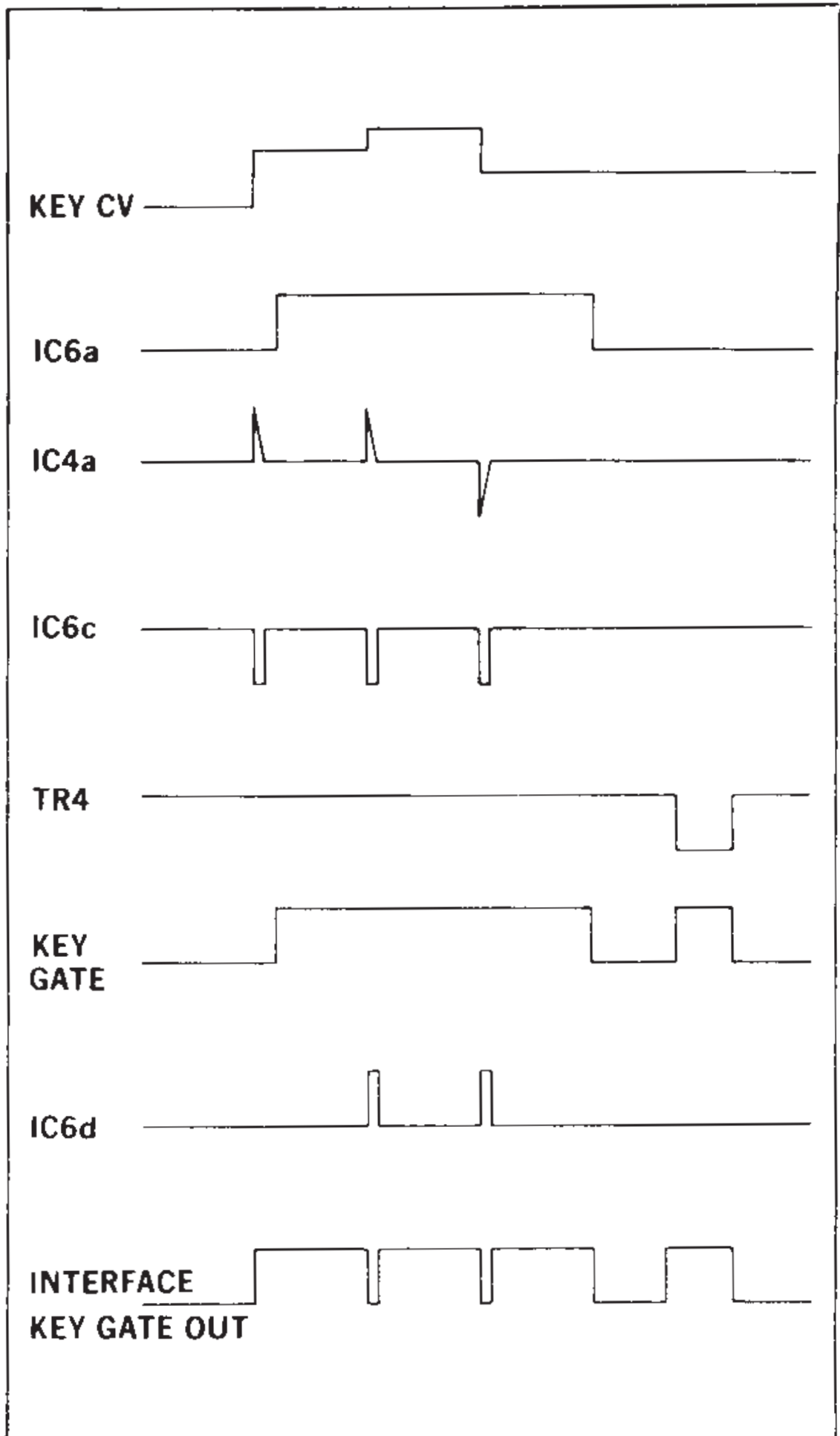

Figure 7. Keyboard controller signals.

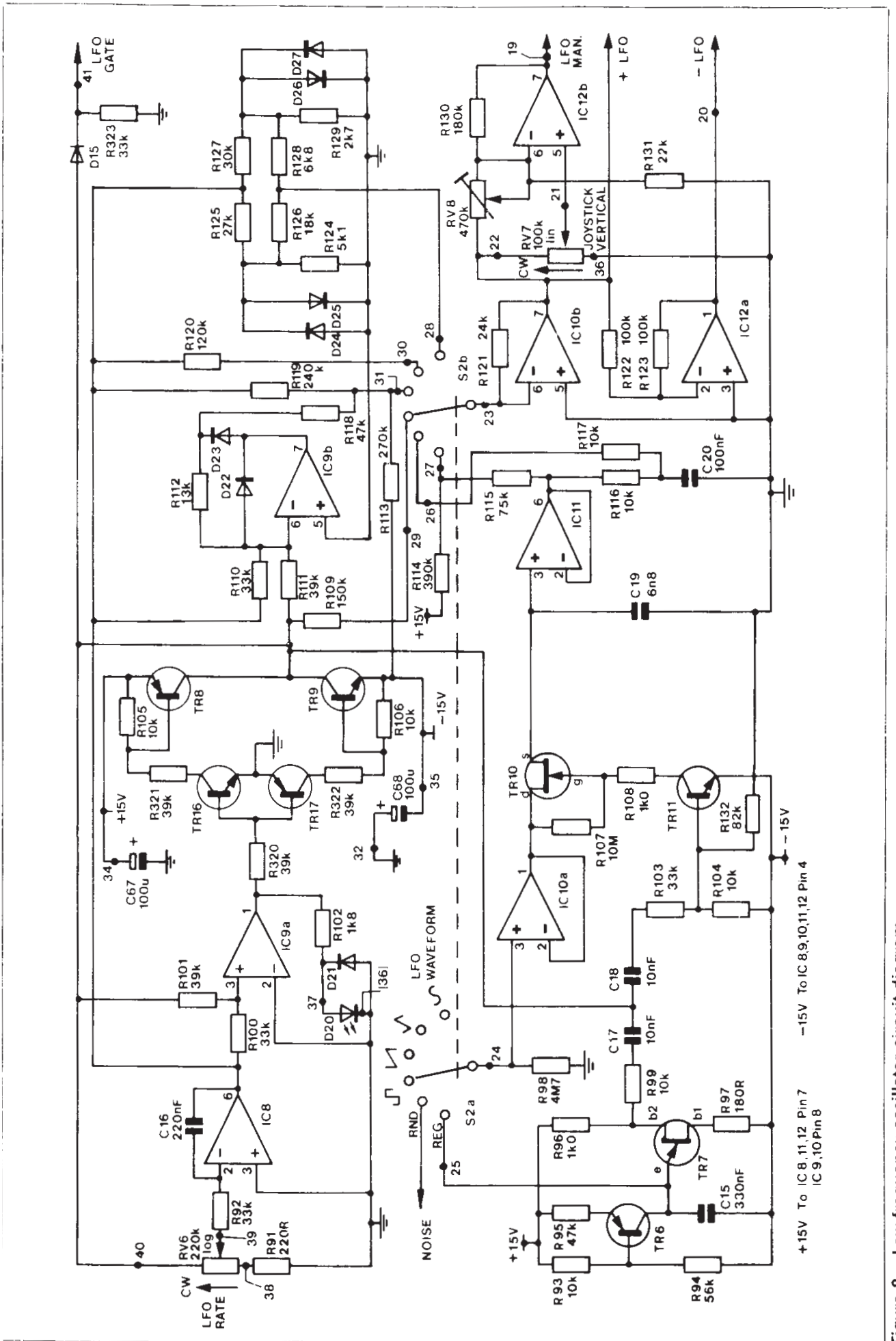

Figure 8. Low frequency oscillator circuit diagram.

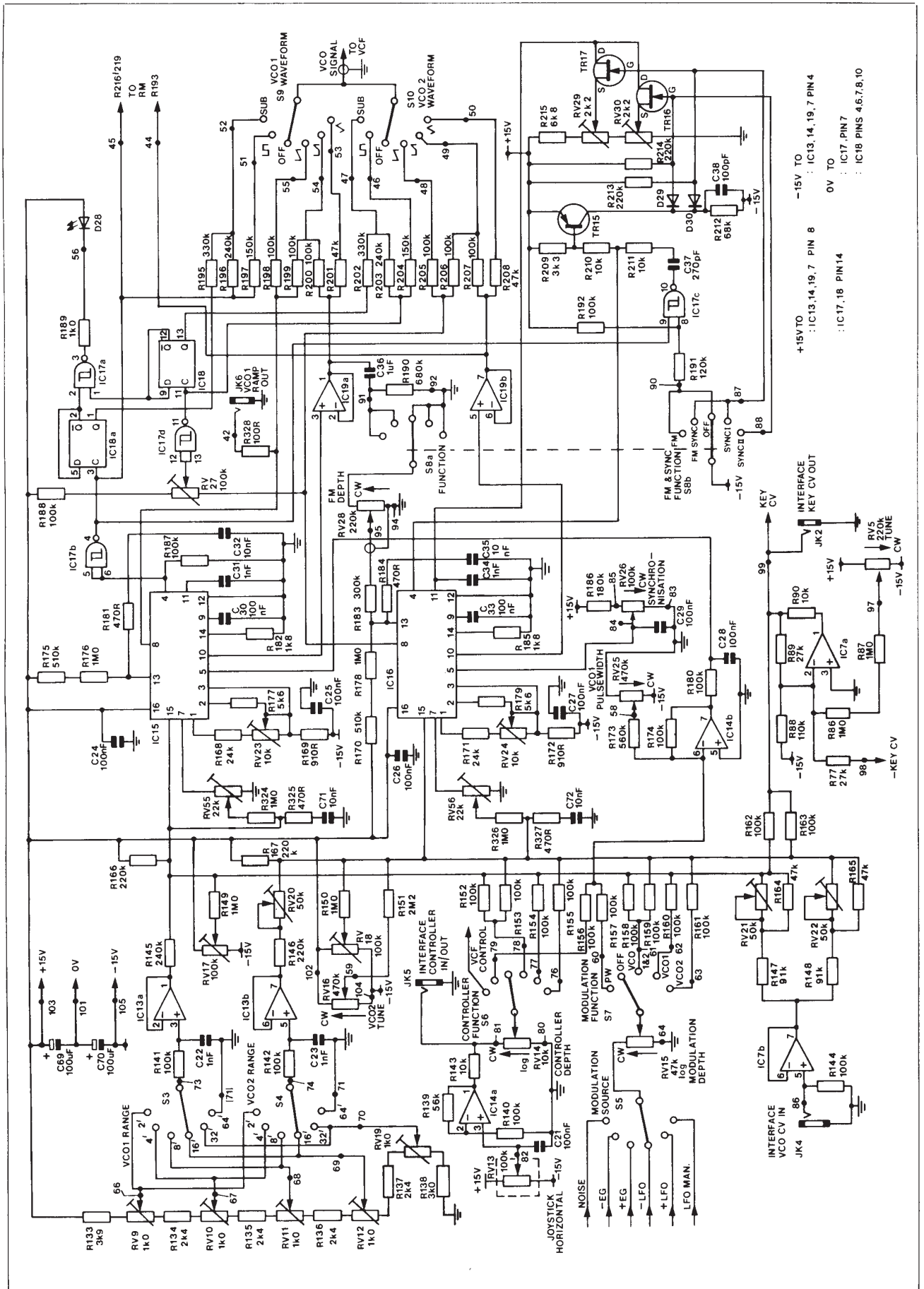

Figure 9. VCOs and their associated circuits.

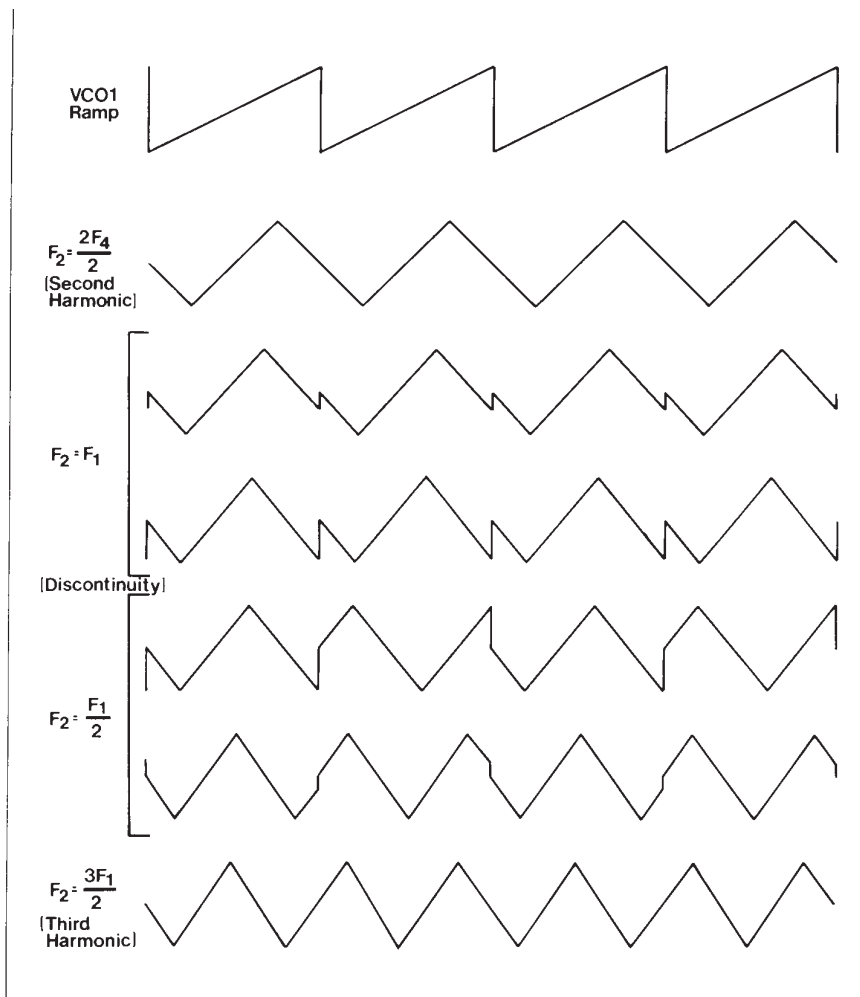

Figure 11. Sync. II.

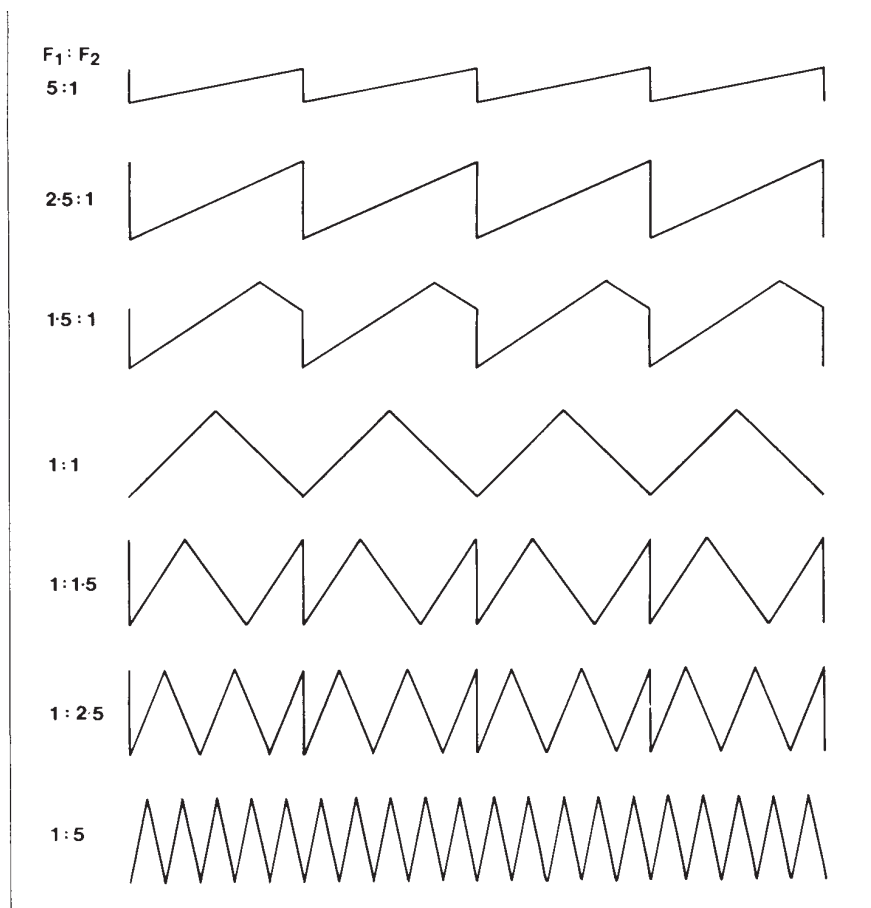

Figure 12. Sync. I.

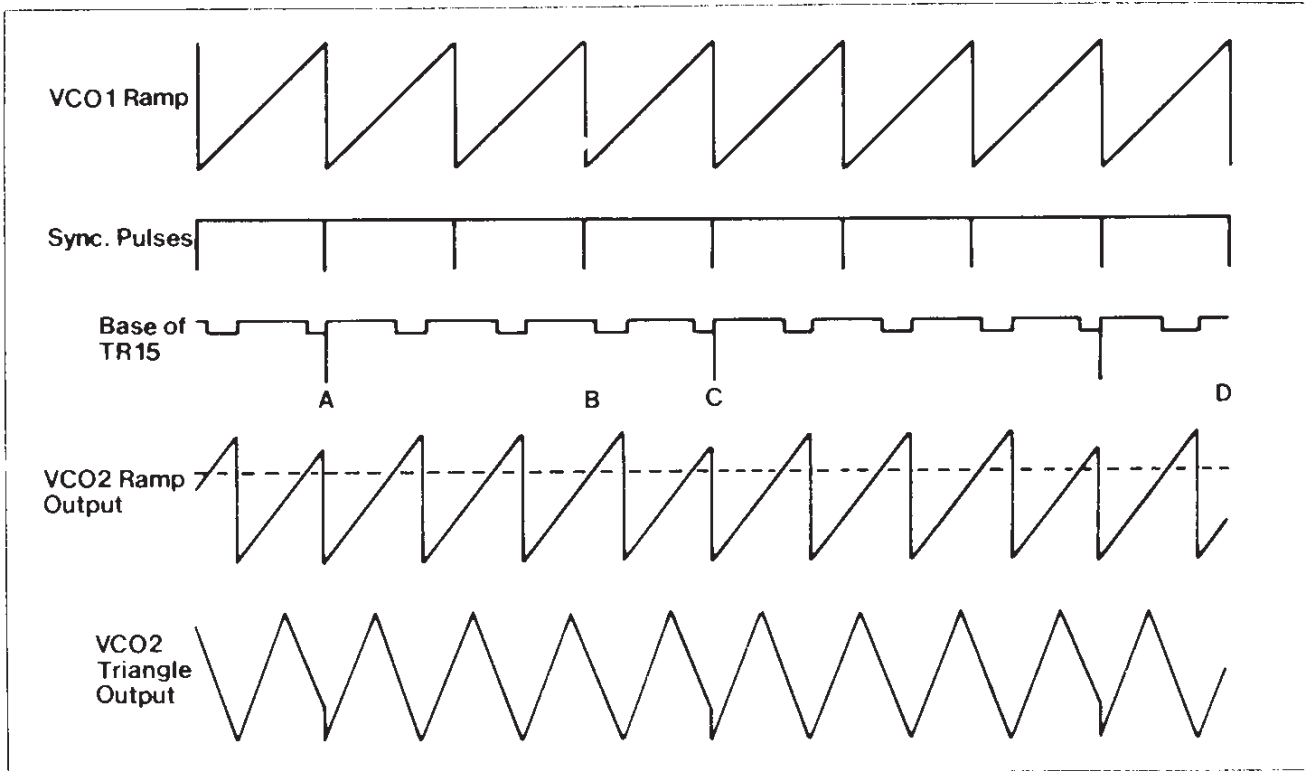

Figure 13. Soft synchronization.

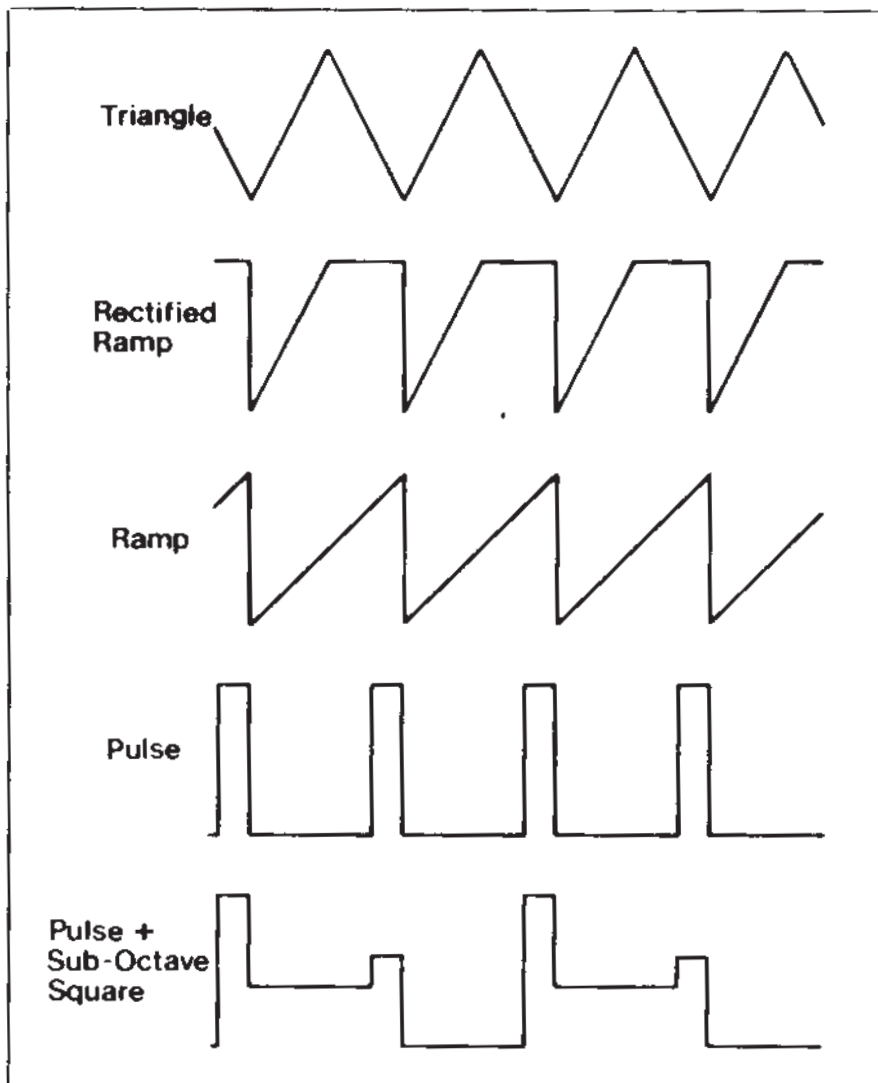

Figure 14. Basic oscillator waveforms.

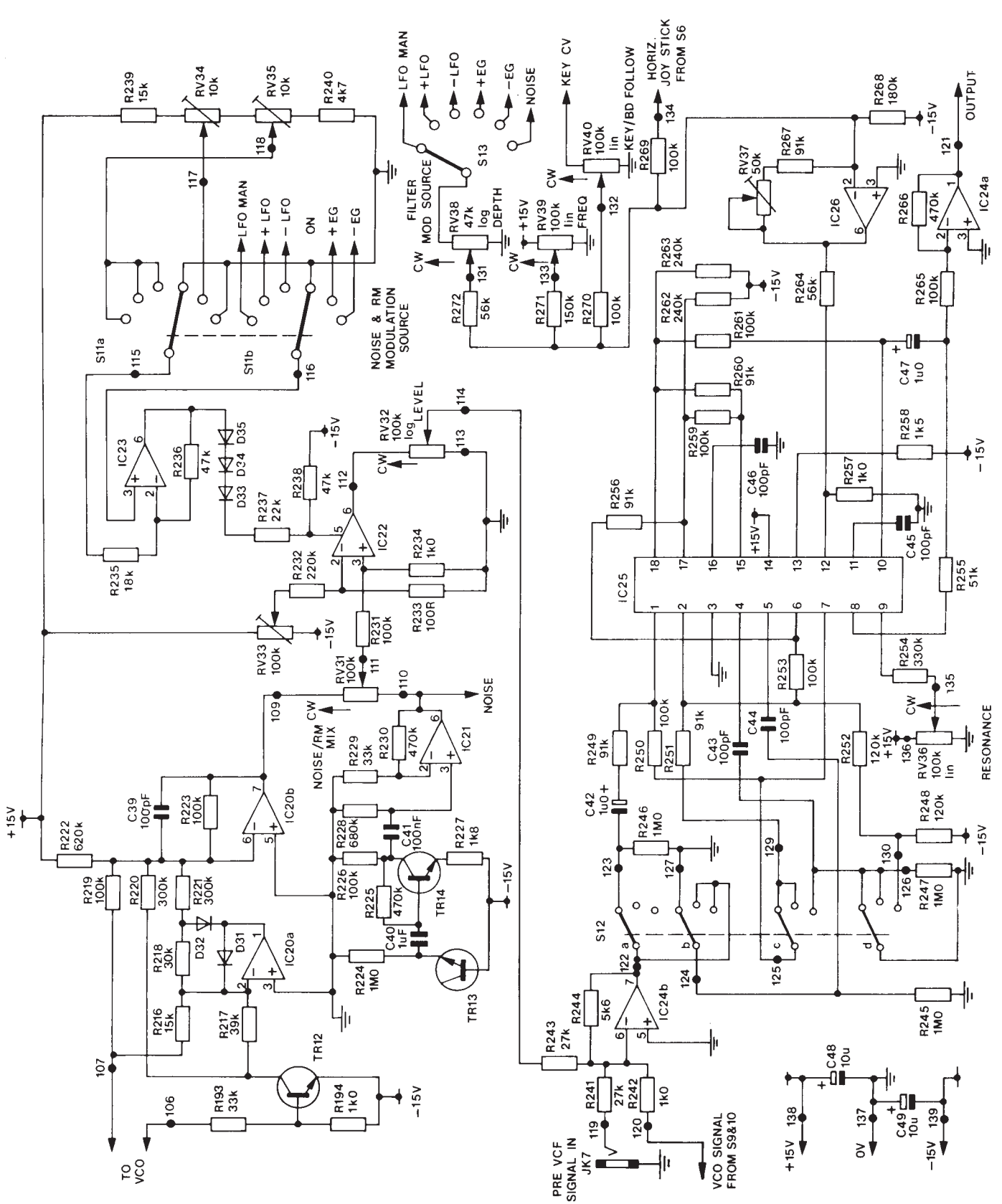

Figure 15. Circuit of the ring modulator, noise generator and filter.

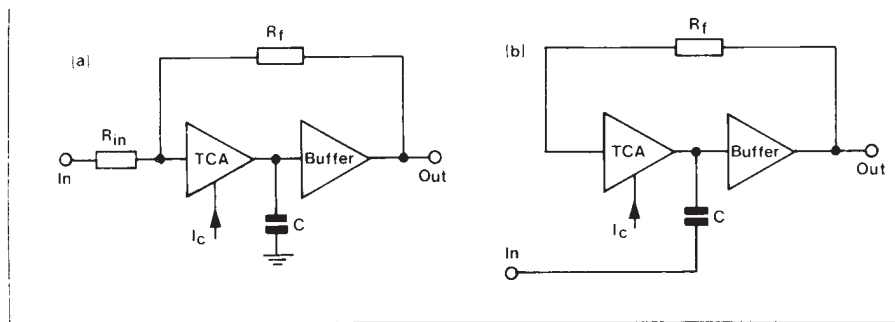

Figure 16. Single filter element of the CEM 3320. a) Low-pass. b) High-pass.

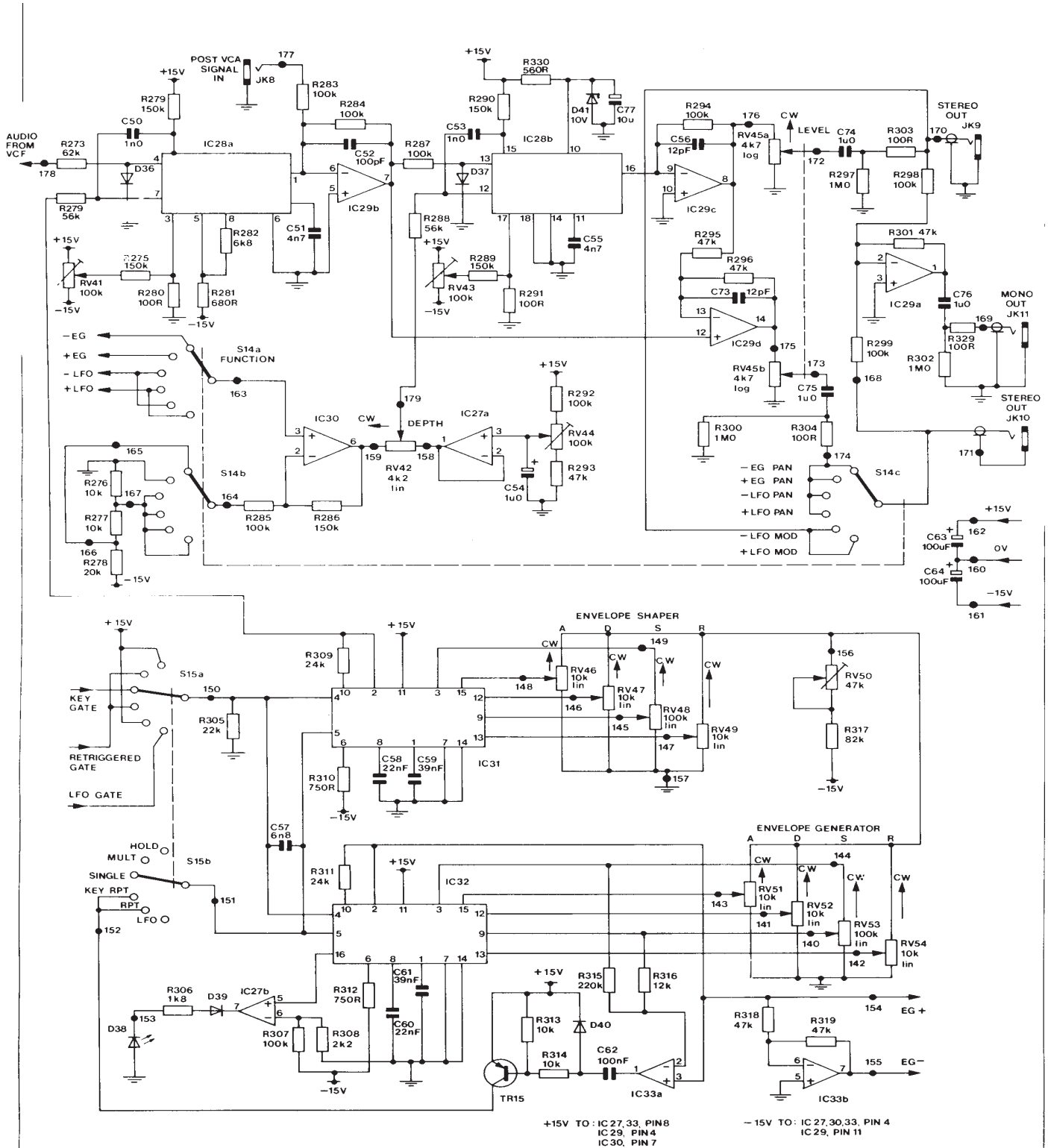

Figure 17. VCAs and envelope generators circuit diagram.

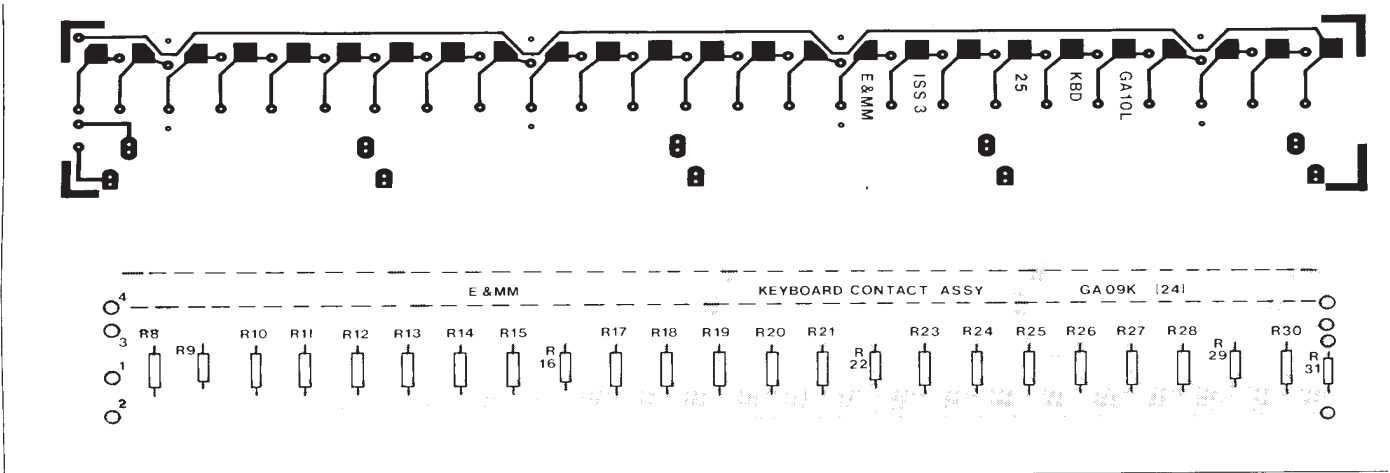
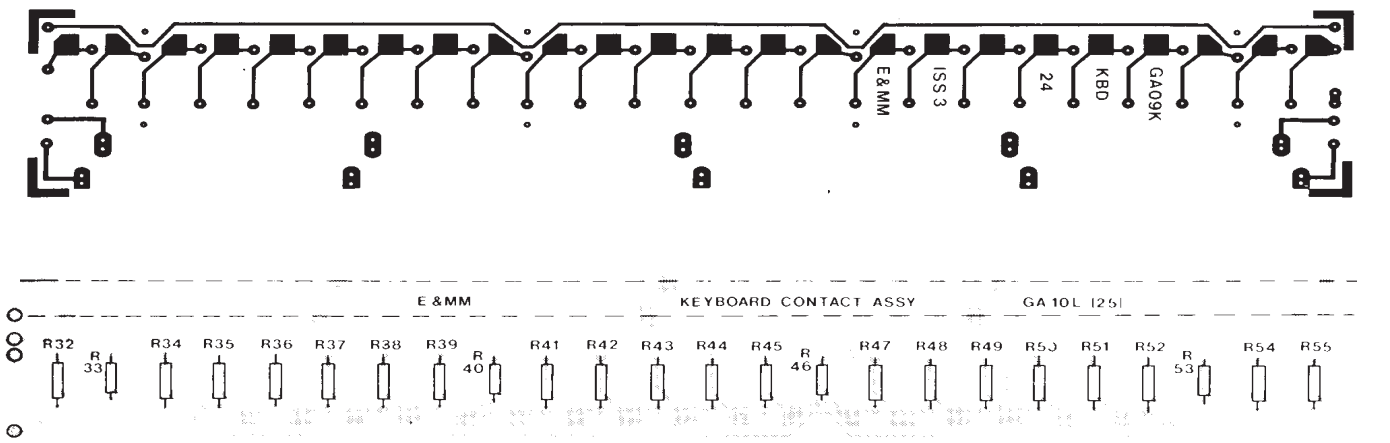

Figure 18. Keyboard PCBs reproduced half size.



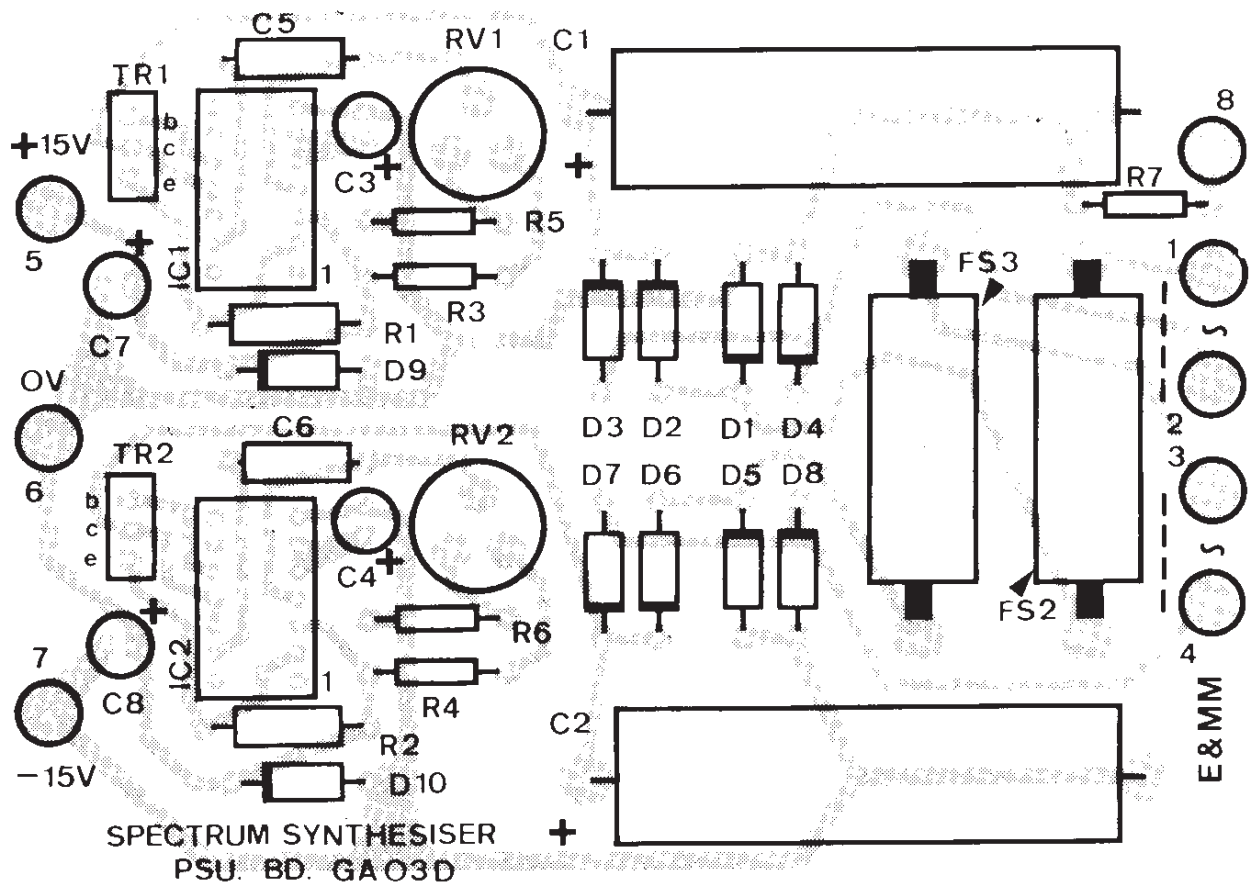
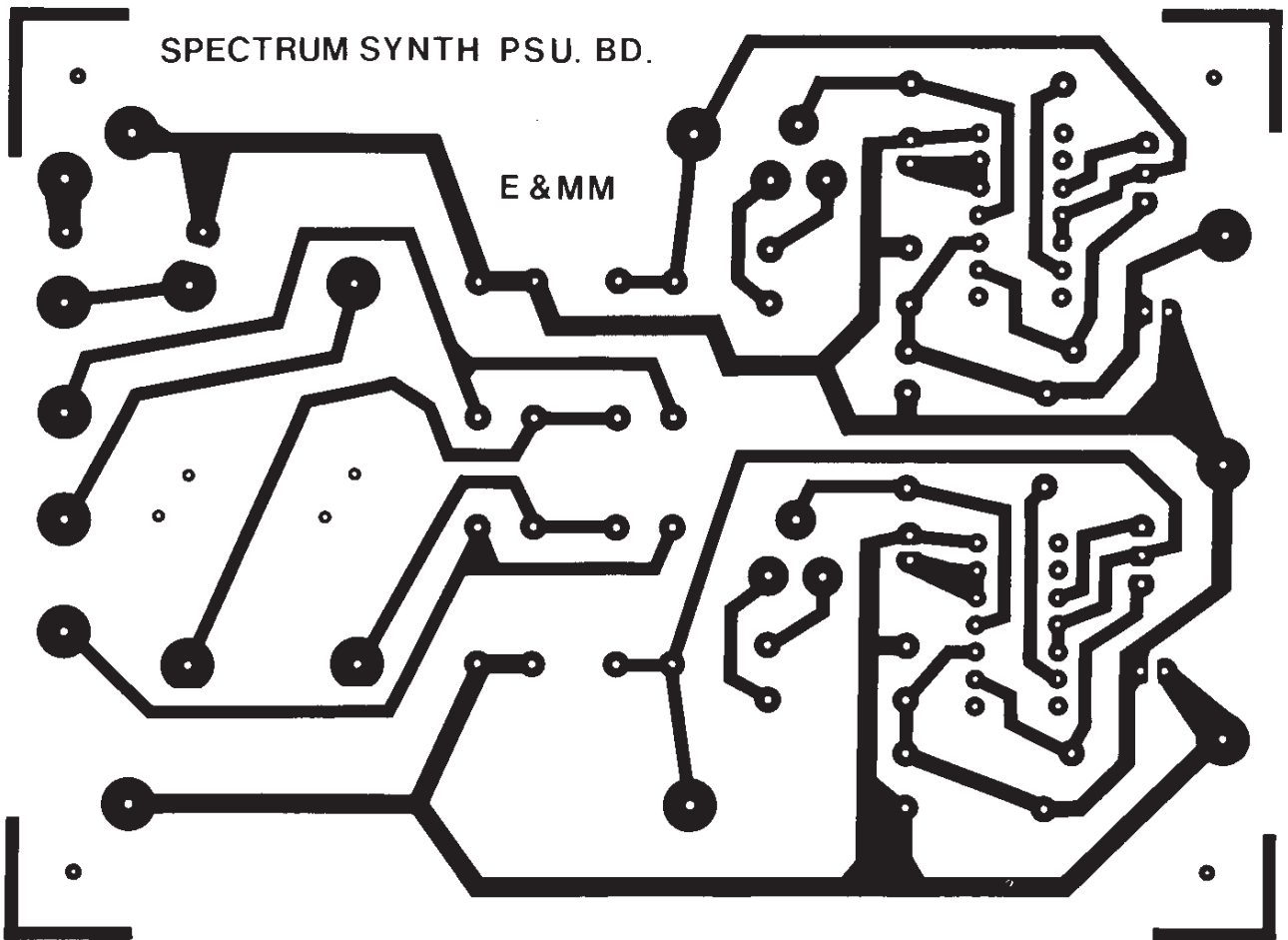

Figure 19. PSU PCB.

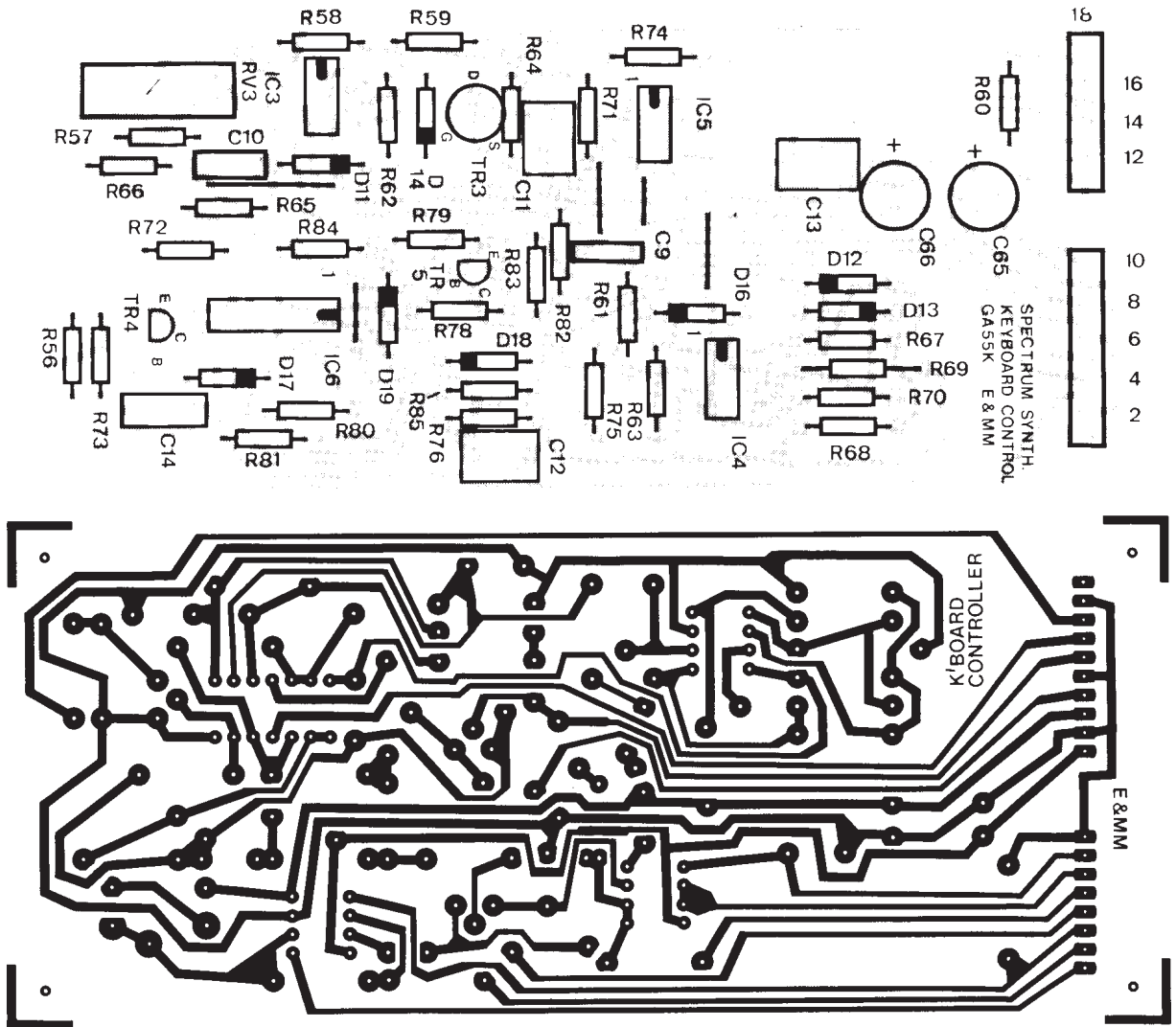

Figure 20. Keyboard controller PCB.

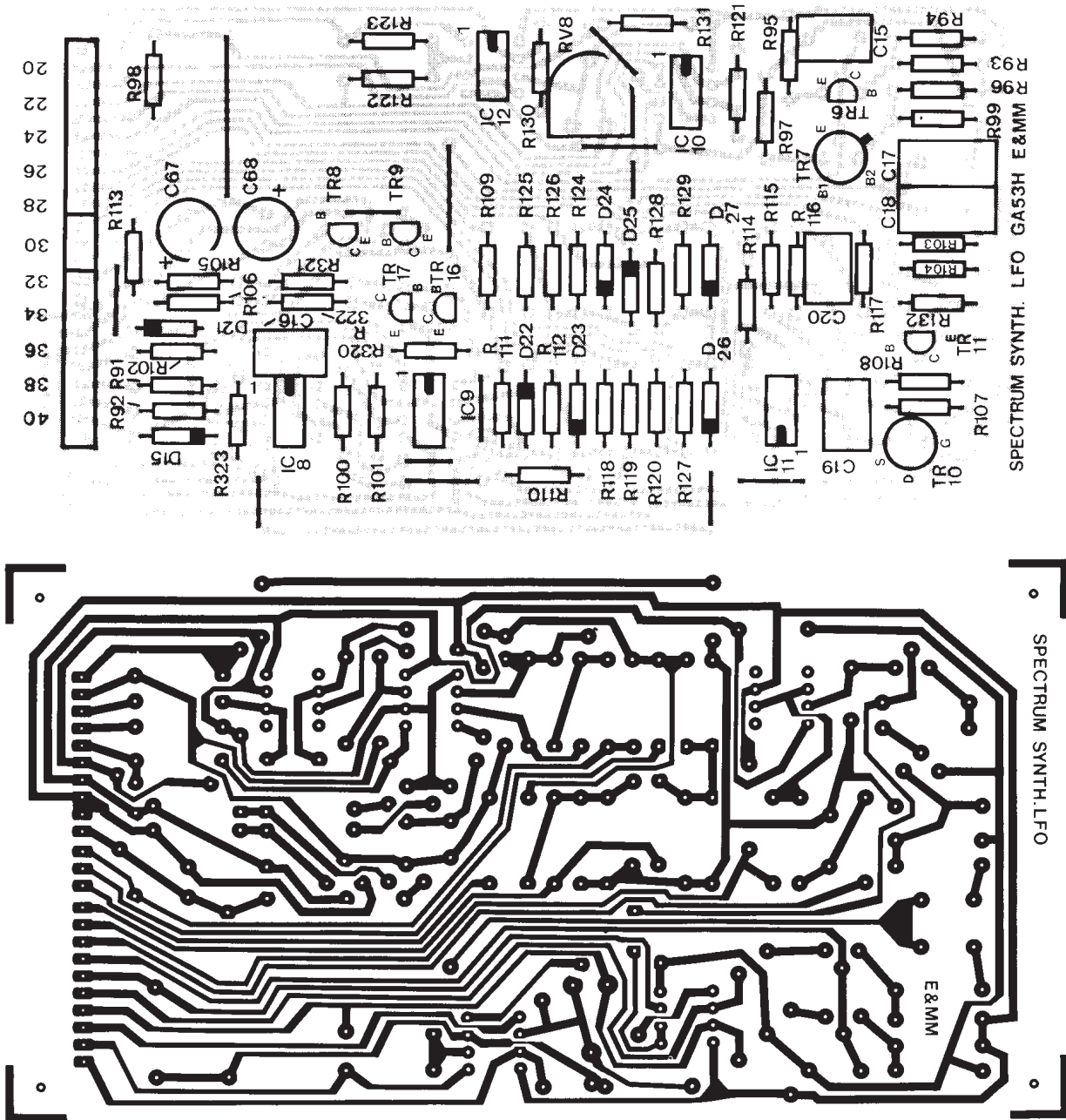

Figure 21. LFO PCB.

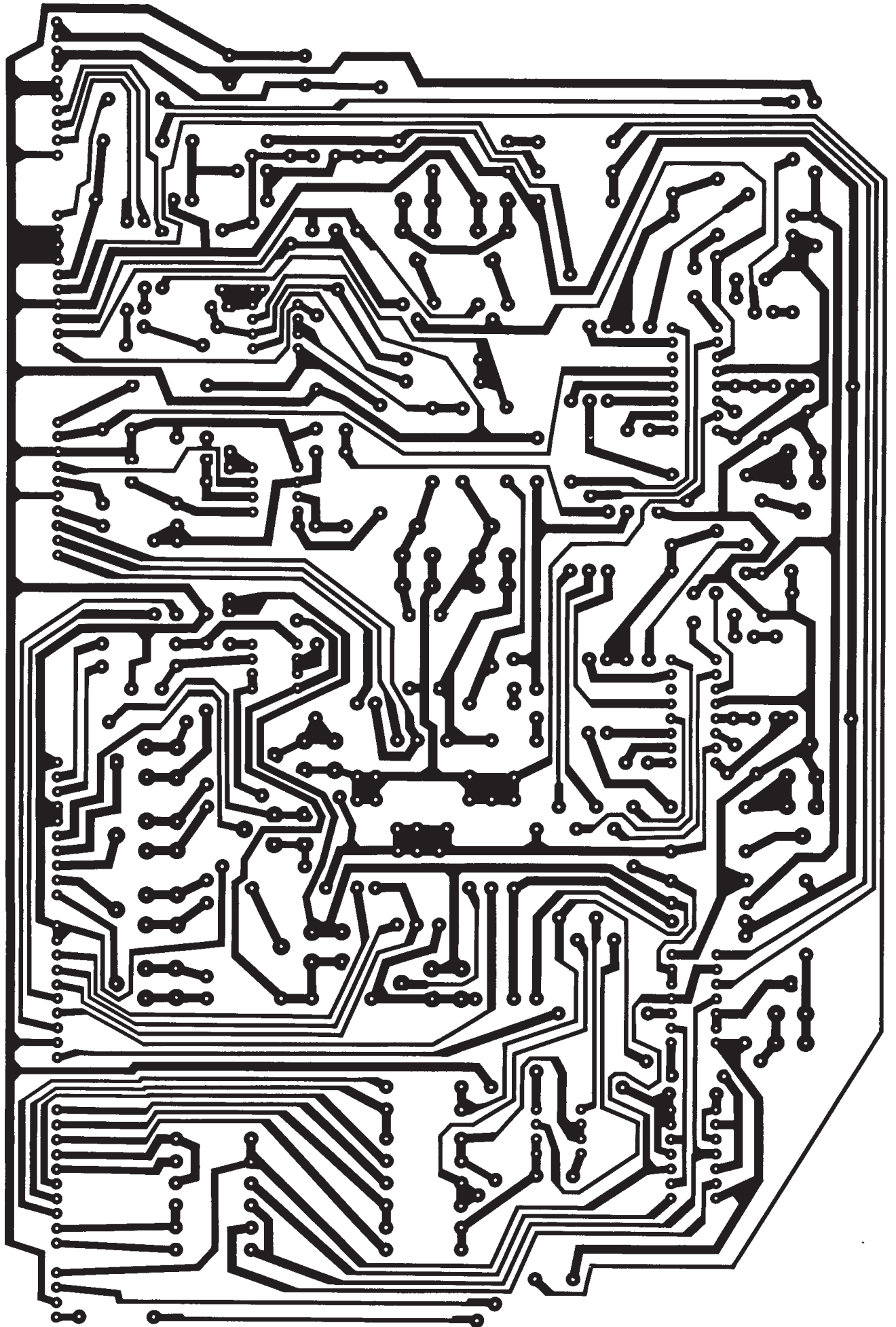
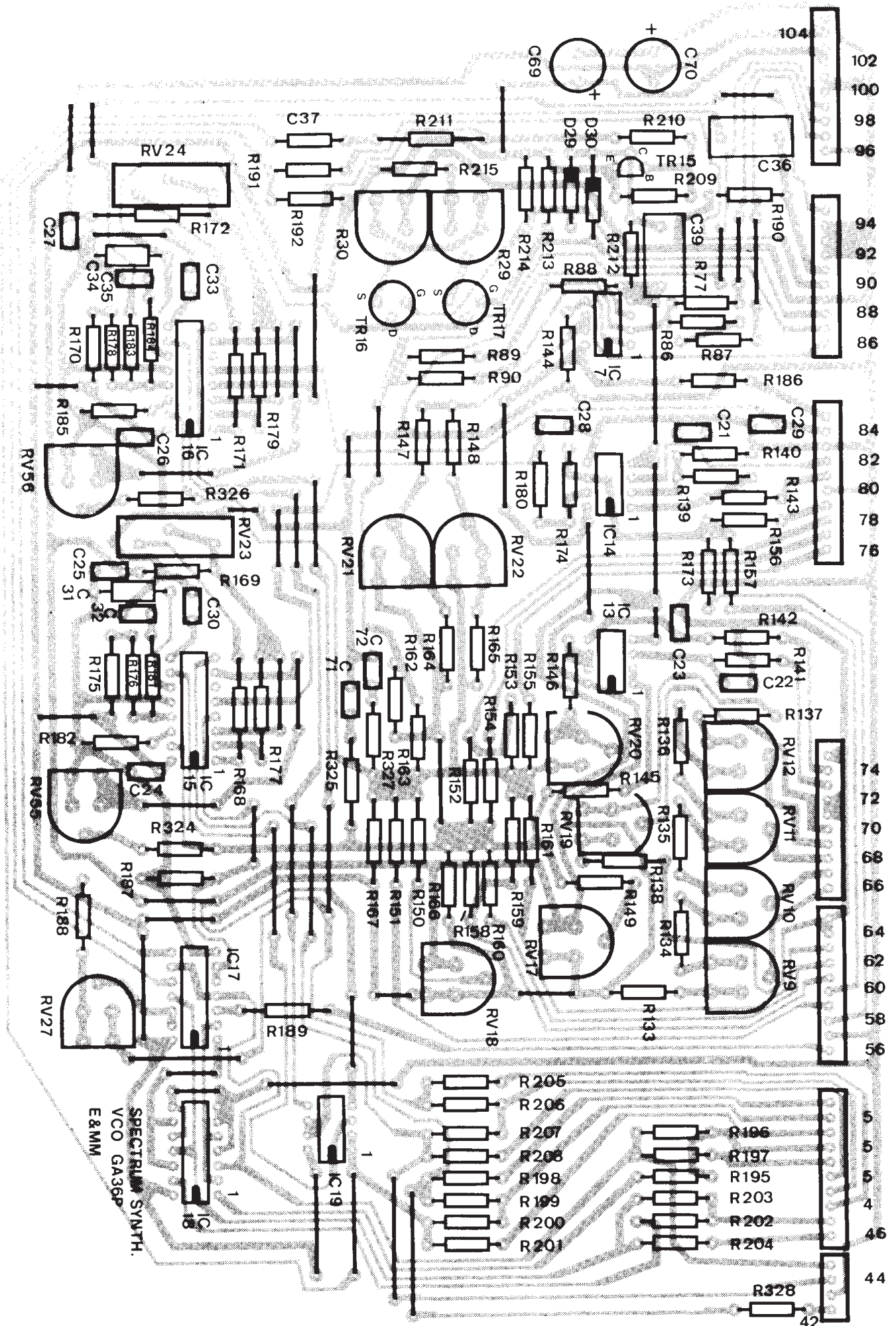

Figure 22. VCO PCB.



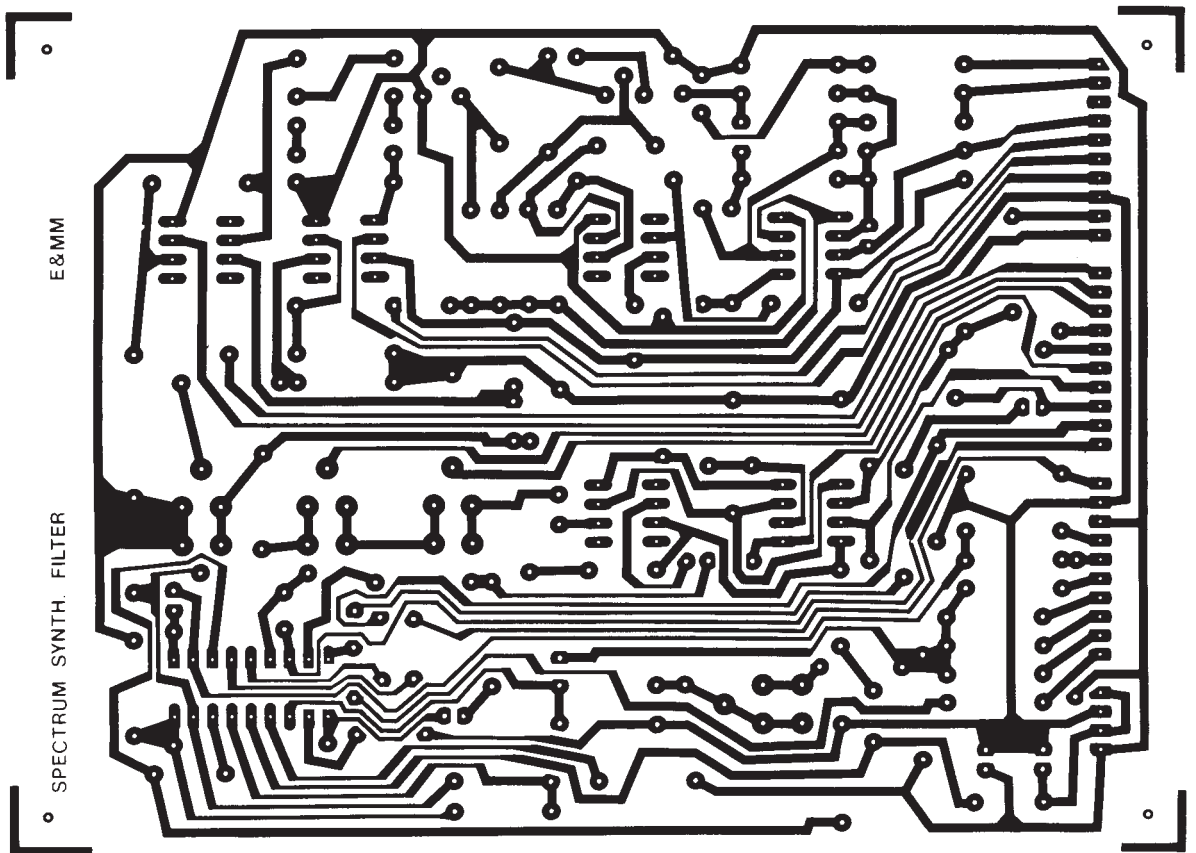
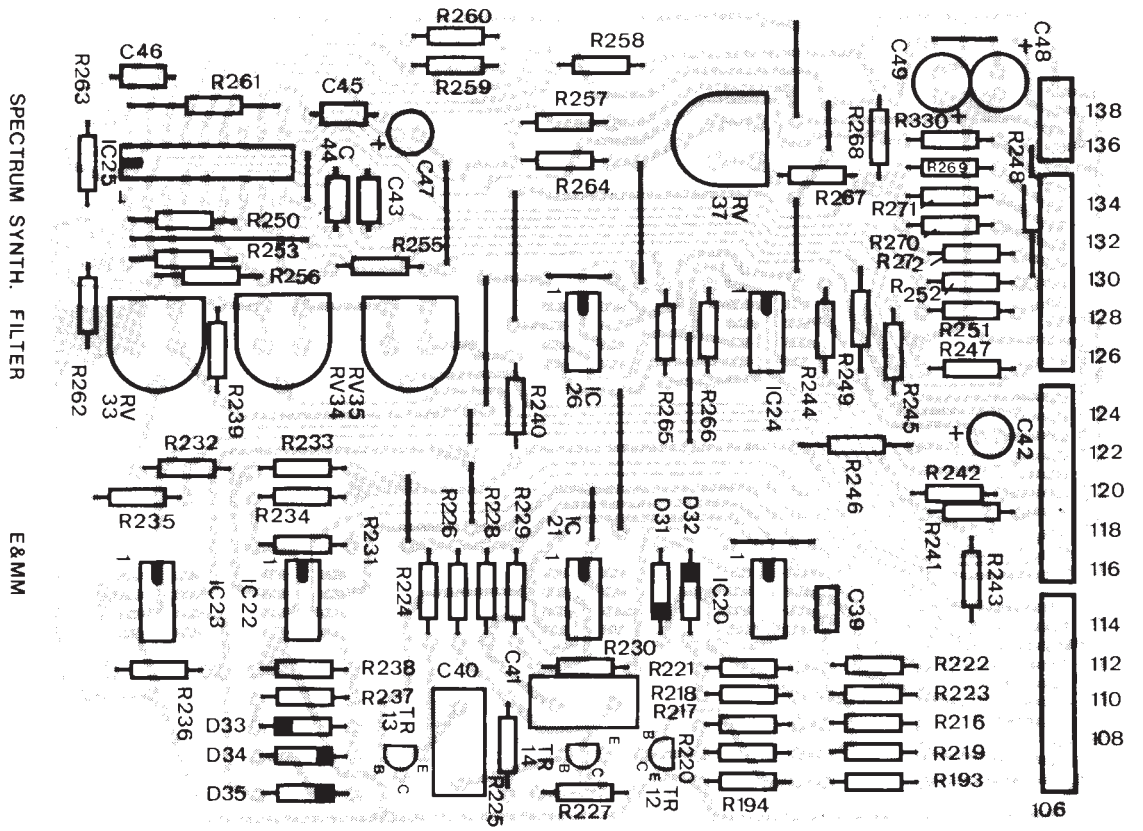

Figure 23. Noise, RM and Filter PCB.

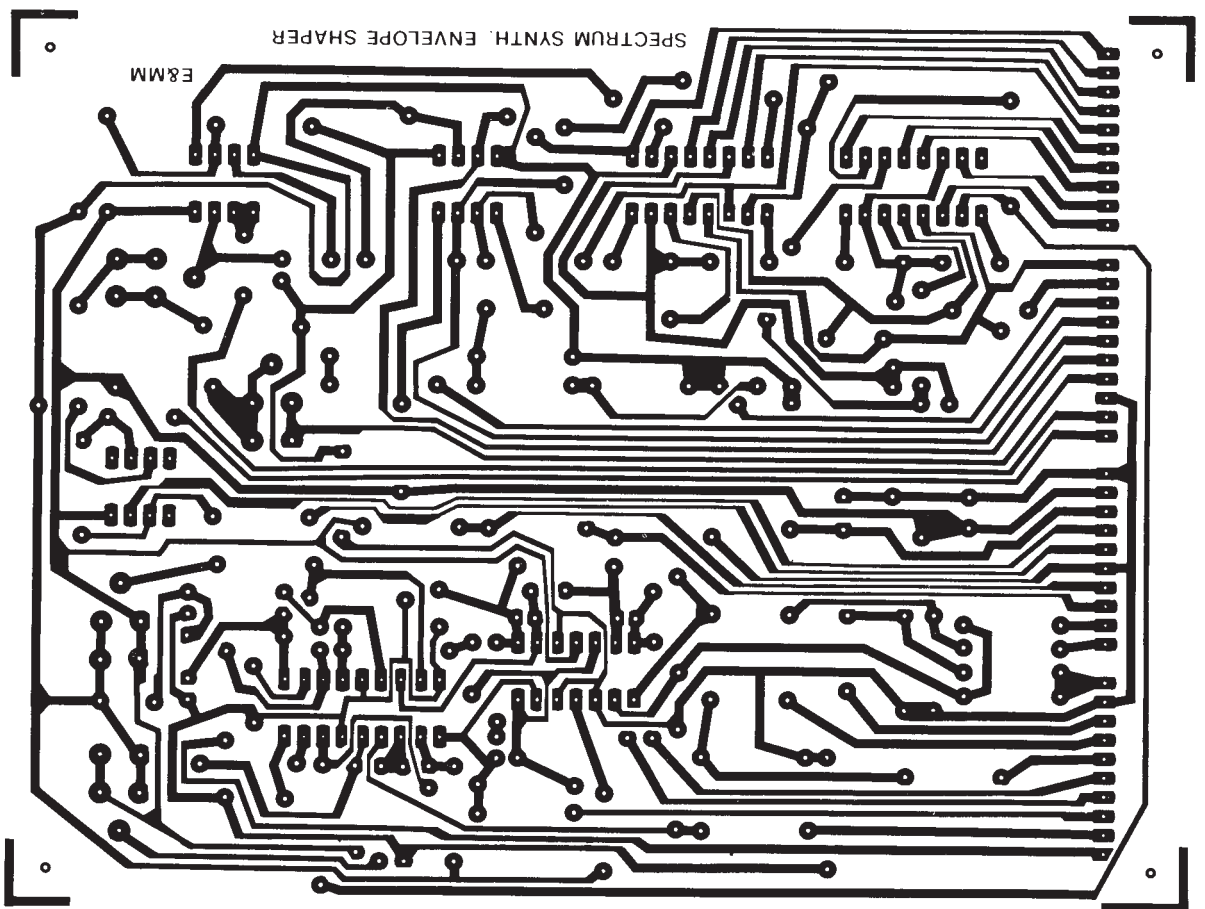
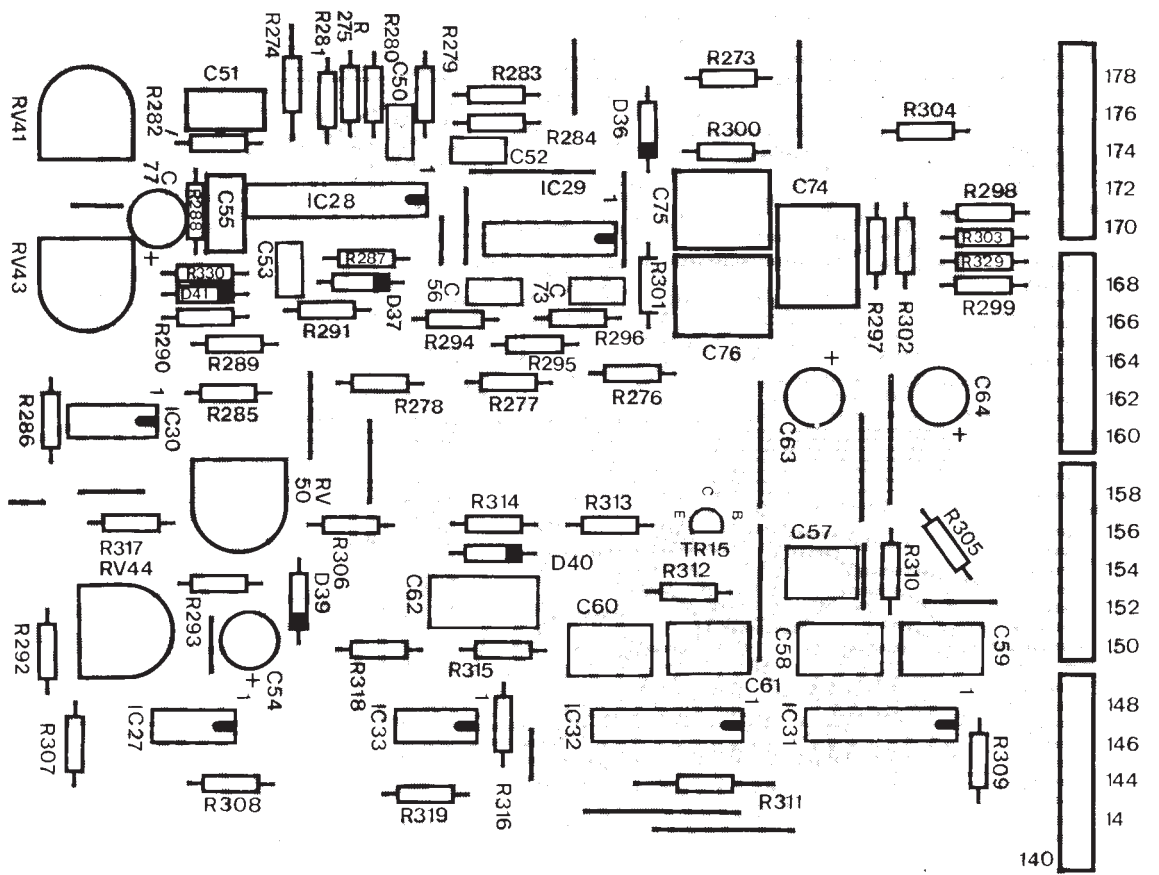

Figure 24. Envelope generator and VCA PCB.

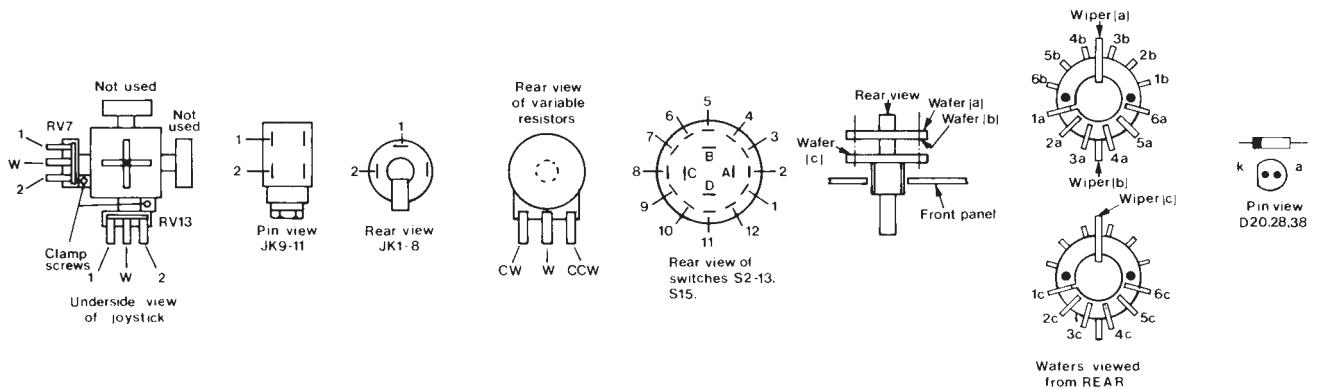
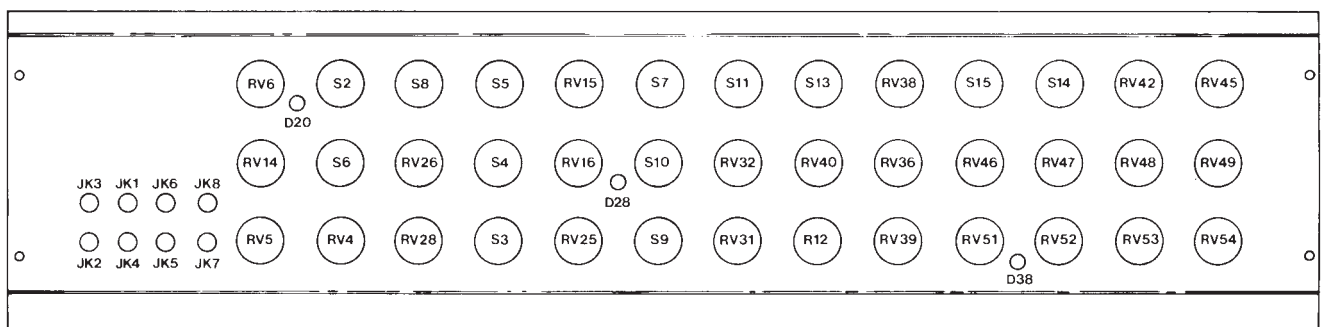
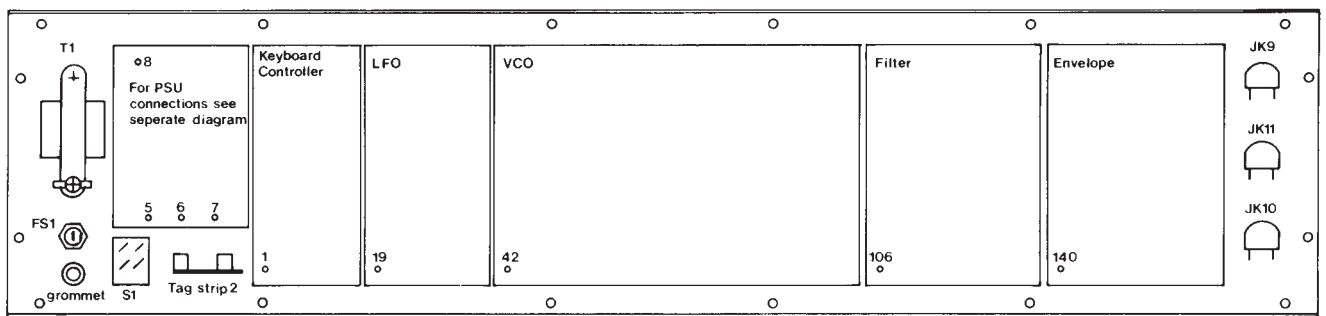
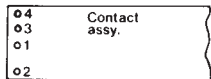
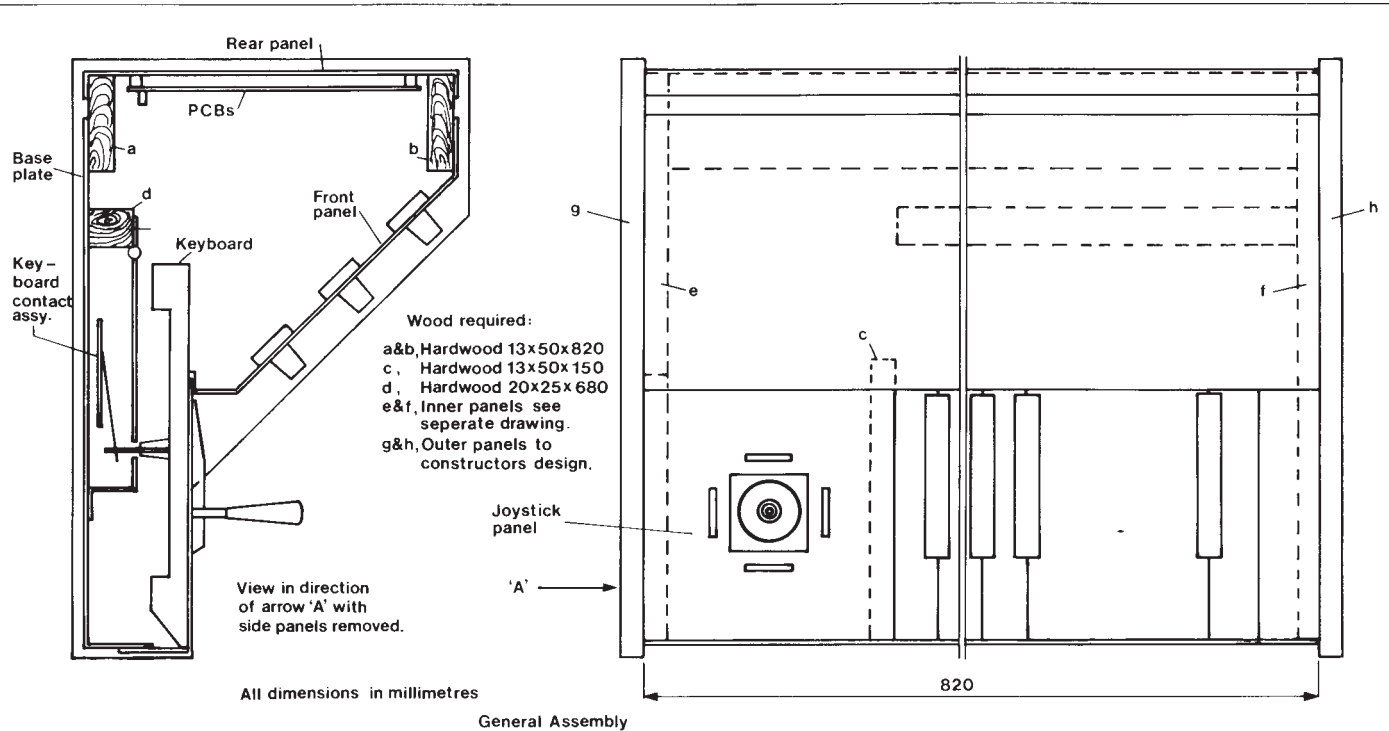
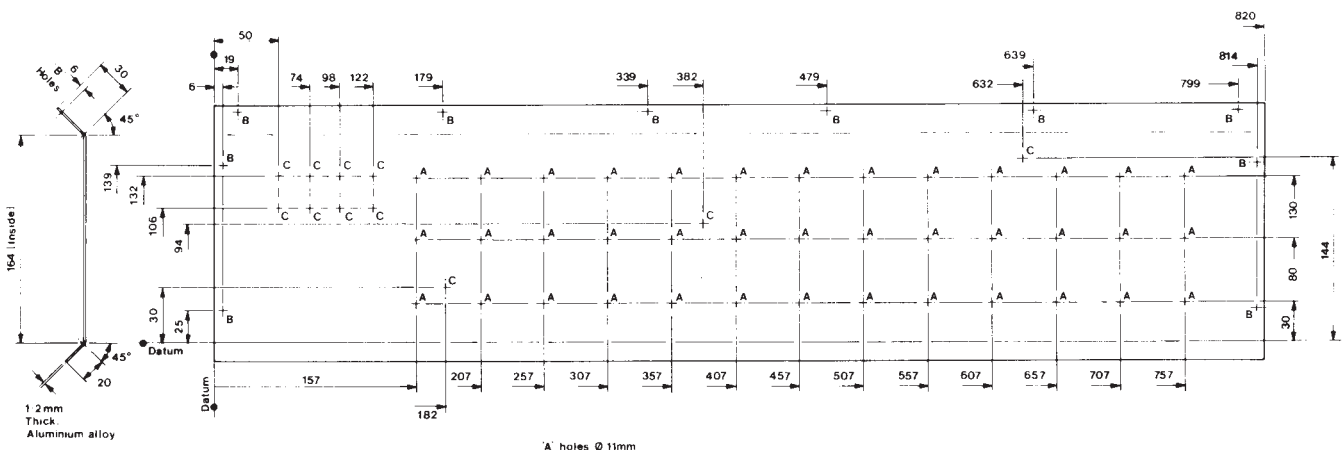

Figure 25. Cabinet construction and panel mounting components.



All dimensions to Datum lines.
All dimensions in millimetres.

A' holes \varnothing 11mm
B' holes \varnothing 4mm
C' holes \varnothing 6.35mm (1/4")

Front Panel. Scale (drawn) 1:2

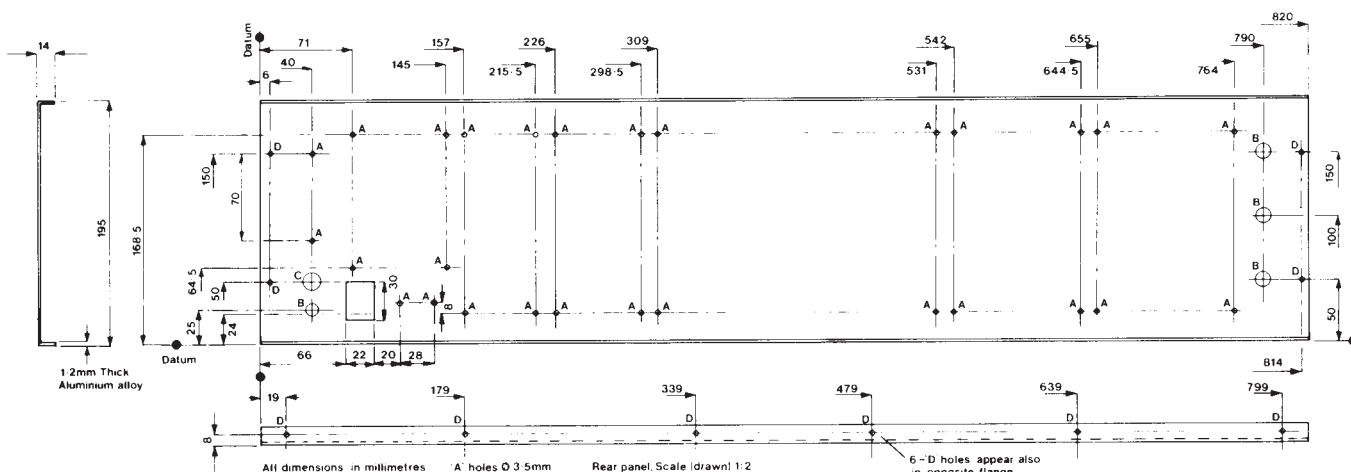

All dimensions in millimetres

A' holes \varnothing 3.5mm
B' holes \varnothing 11mm
C' hole \varnothing 13mm
D' hole \varnothing 4mm

Rear panel. Scale (drawn) 1:2

6 -D holes appear also in opposite flange.

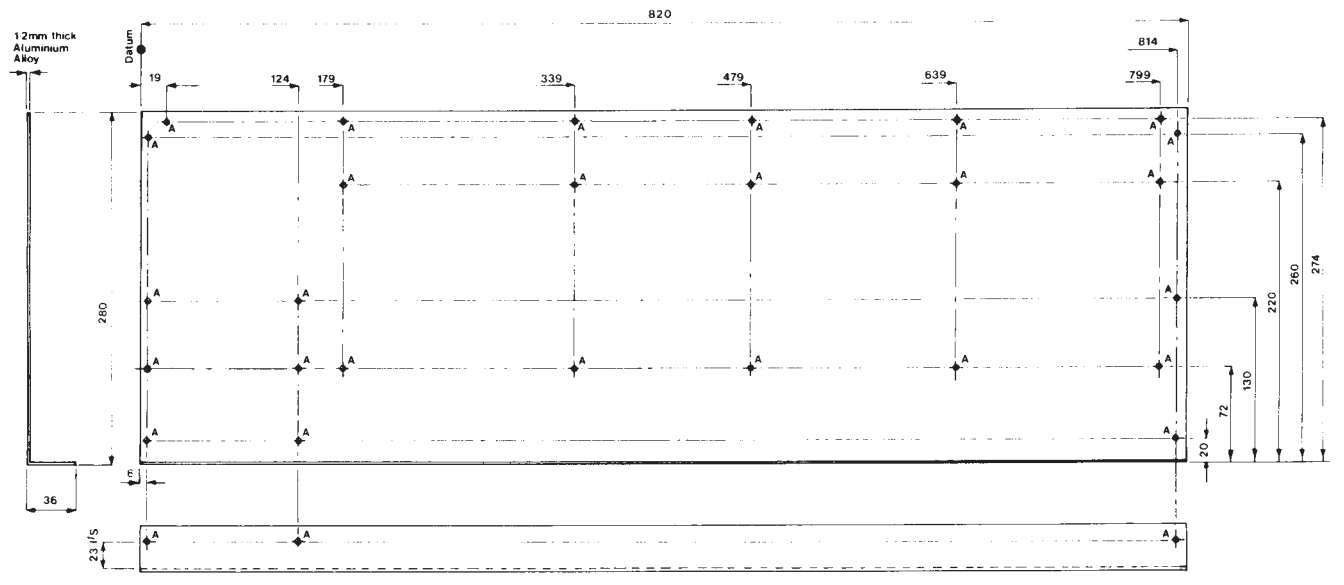

All dimensions in millimetres

A' holes \varnothing 4mm

Base plate. Scale (drawn) 1:2

Figure 26. Metalwork details.

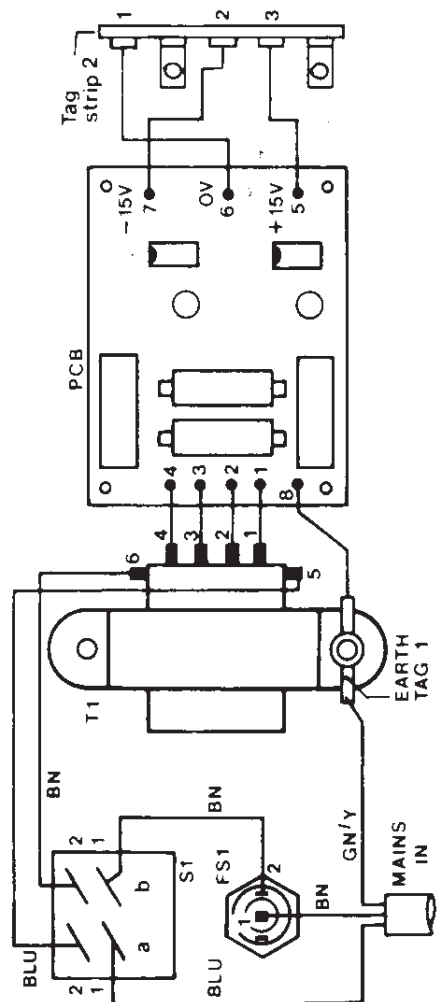
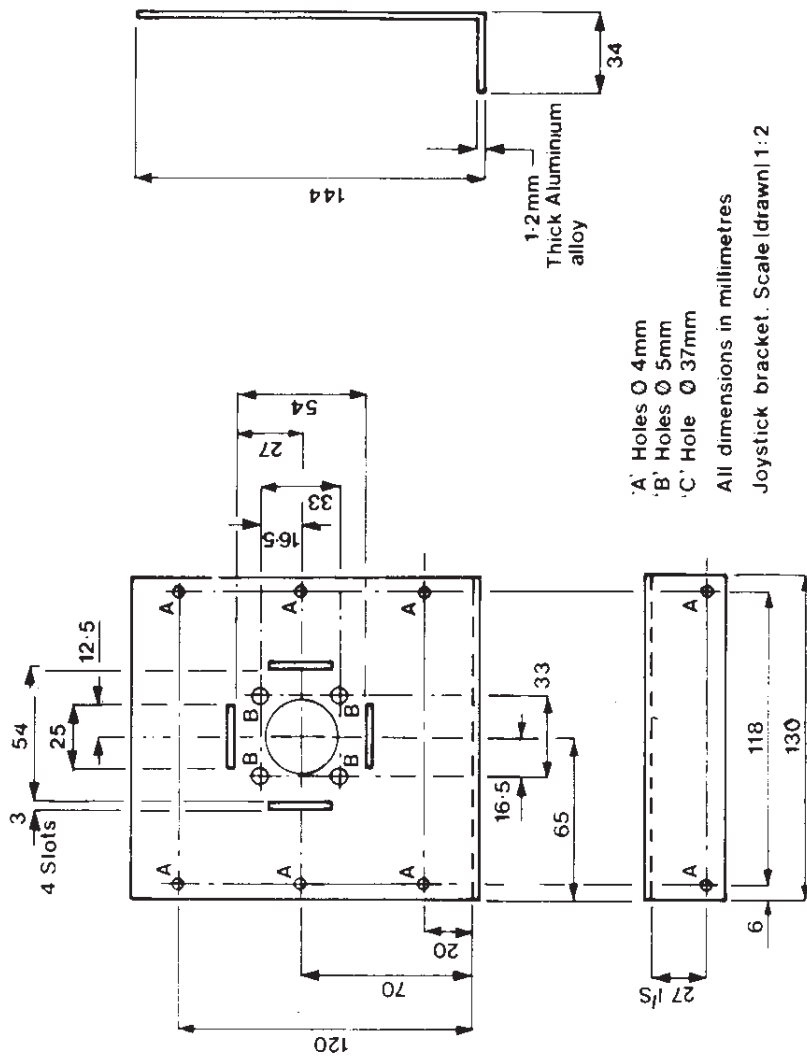
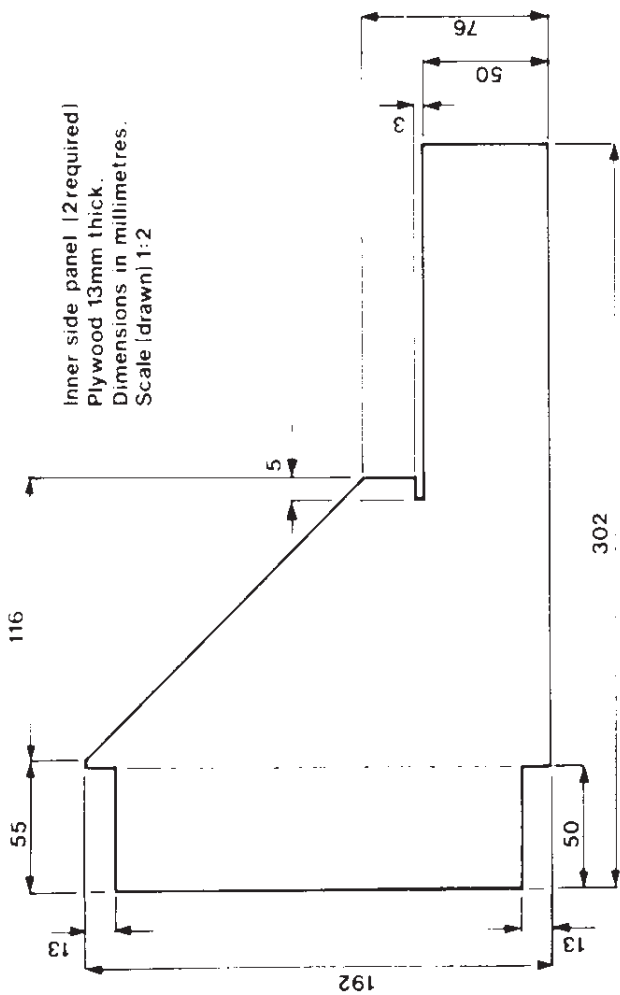

INTERFACE

KEY CV OUT
VCO CV IN
CONTROLLER CV IN/OUT
PRE VCO SIGNAL IN
KEY GATE OUT
LATCH IN
VCO HAMP OUT
POST VCA SIGNAL IN

KEYBOARD

TUNE
GLIDE

FM & SYNC

FM DEPTH

VOLTAGE CONTROLLED OSCILLATOR 1

RANGE
PULSE WIDTH
WAVEFORM

CONTROLLER

DEPTH
FUNCTION

SYNCHRONISATION

FUNCTION

VOLTAGE CONTROLLED OSCILLATOR 2

RANGE
TUNE
WAVEFORM

**E&MM
SPECTRUM
SYNTHESISER**

LOW FREQUENCY OSCILLATOR

HATE
WAVEFORM

FUNCTION

SYNCD
SYNCS
OFF
FM SYNC 1
FM

OSCILLATOR MODULATION

SOURCE
NOISE
DEPTH
FUNCTION

NOISE & RM

NOISE
LEVEL
SOURCE

VOLTAGE CONTROLLED FILTER

RESPONSE
FREQUENCY
RESONANCE
DEPTH

ENVELOPE GENERATOR

ATTACK
DECAY
SUSTAIN
RELEASE

ENVELOPE SHAPER

ATTACK
DECAY
SUSTAIN
RELEASE

GATE

MODE

OUTPUT

FUNCTION
DEPTH
LEVEL

The SPECTRUM SYNTHESIZER



- ★ Low Cost
- ★ FM and Sync.
- ★ Stereo Outputs
- ★ Sequencer Effects
- ★ Easy to Construct
- ★ Interface Facilities
- ★ Four Octave Keyboard
- ★ Performance Controller

KEYBOARD PARTS LIST

Resistors			
R8-55	47R 2%	48 off	(X47R)
Miscellaneous			
	49-note C-C keyboard		(XB17T)
	Contact springs	49 off	(QY07H)
	Palladium bars, 1.2mm x 330mm	Set of 4	
	24-contact PCB		(GA09K)
	25-contact PCB		(GA10L)
	6BA 1" bolts		(BF67H)
	6BA 1/2" spacers		(FW35Q)
	6BA washers		(BF22Y)
	6BA nuts		(BF18U)
	Veropins		(FL24B)

POWER SUPPLY UNIT PARTS LIST

Resistors — 5% 1/2W carbon unless specified.			
R1,2	2R2 1/2W	2 off	(S2R2)
R3,4	3k3 1%	2 off	(T3K3)
R5,6	3k0 1%	2 off	(T3K0)
R7	330R		(M330R)
RV1,2	1k cermet preset	2 off	(WR40T)
Capacitors			
C1,2	2200uF 25V axial elect.	2 off	(FB90X)
C3,4,7,8	2u2 63V PC elect.	4 off	(FF02C)
C5,6	100pF polystyrene		(BX28F)
Semiconductors			
IC1,2	uA723 14-pin DIL	2 off	(QL21X)
TR1,2	BD135	2 off	(QF06G)
D1-D10	1N4001	10 off	(QL73Q)

Miscellaneous									
T1	240V prim. 0-15, 0-15 sec. 10VA		(LY03D)	R170,175	510k 1% film		2 off	(T510K)	
S1	DPST rocker switch with neon		(YR70M)	R173	560k			(M560K)	
FS1	20mm 500mA quick blow fuse		(WR02C)	R177,179	5k6 1% film		2 off	(T5K6)	
	20mm panel fuseholder		(RX96E)	R181,184,325,					
FS2,3	20mm 1A quick blow fuse	2 off	(WR03D)	327	470R		4 off	(M470R)	
	20mm chassis fuseholder	2 off	(RX49D)	R182,185	1k8 1% film		2 off	(T1K8)	
	14-pin DIL socket	2 off	(BL18U)	R183	300k ½W			(S300K)	
	PCB		(GA03D)	R186	180k			(M180K)	
	3A 3-core mains cable 2m		(XR01B)	R189	1k0			(M1K0)	
	13A mains plug		(HL58N)	R190	680k			(M680K)	
	6BA 1" bolts		(BF07H)	R191	120k			(M120K)	
	6BA ½" spacers		(FW35Q)	R195,202	330k		2 off	(M330K)	
	6BA nuts		(BF18U)	R196,203	240k ½W		2 off	(S240K)	
	4BA ½" bolts		(BF03D)	R197,204	150k		2 off	(M150K)	
	4BA nuts		(BF17T)	R201,208	47k		2 off	(M47K)	
	4BA solder tags		(BF28F)	R209	3k3			(M3K3)	
	Cable grommet		(LR48C)	R212	68k			(M68K)	
	Veropins		(FL24B)	R213,214	220k		2 off	(M220K)	

KEYBOARD CONTROLLER PARTS LIST

Resistors — 5% ½W carbon unless specified									
R56	33k		(M33K)	RV9,10,11,12,19	1k0 cermet preset		5 off	(WR40T)	
R57	5k6 1% film		(T5K6)	RV14	10k log. pot.			(FW22Y)	
R58,59	470R 1% film	2 off	(T470R)	RV15	47k log. pot.			(FW24B)	
R60	1M0		(M1M0)	RV16,25	470k lin. pot.		2 off	(FW07H)	
R61,85	4k7	2 off	(M4K7)	RV17,18	100k cermet preset		2 off	(WR44X)	
R62,75	1k0	2 off	(M1K0)	RV20,21,22	50k cermet preset		3 off	(WR43W)	
R63	470k		(M470K)	RV23,24	10k multi-turn cermet preset		2 off	(WR49D)	
R64,74	100R	2 off	(M100R)	RV26	100k lin. pot.			(FW05F)	
R65,66,78,79	10k	4 off	(M10K)	RV27	100k min. horiz. preset			(WR61R)	
R67,70,73,80	100k	4 off	(M100K)	RV5,28	220k lin. pot.		2 off	(FW06G)	
R68,69	3k3	2 off	(M3K3)	RV29,30	2k2 min. horiz. preset		2 off	(WR56L)	
R71	10M 10%		(M10M)	RV55,56	22k min. horiz. preset		2 off	(WR59P)	
R72	220k		(M220K)	Capacitors — monolithic ceramic unless specified					
R76	47k		(M47K)	C21,24,25,26,27,					
R81	330k		(M330K)	28,29,30,33	100nF		9 off	(YY11M)	
R82,84	22k	2 off	(M22K)	C22,23	1nF		2 off	(YY24B)	
R83	2k2		(M2K2)	C31,34	1nF 1% polystyrene		2 off	(BX56L)	
RV3	5k0 multi-turn cermet preset		(WR48C)	C32,35,71,72	10nF		4 off	(YY08J)	
RV4	2M2 log. pot.		(FW29G)	C36	1uF polycarb.			(WW53H)	
Capacitors — polycarbonate unless specified									
C9	68nF		(WW39N)	C37	270pF ceramic plate			(WX61R)	
C10,12,14	100nF	3 off	(WW41U)	C38	100pF polystyrene			(BX28F)	
C11,13	470nF	2 off	(WW49D)	C69,70	100uF 25V PC elect.		2 off	(FF11M)	
C65,66	100uF 25V PC elect.	2 off	(FF11M)	Semiconductors					
Semiconductors									
IC3,4	1458C	2 off	(QH46A)	IC7,14,19	1458C		3 off	(QH46A)	
IC5	CA3240E		(WQ21X)	IC13	LF353 or TL082			(WQ31J)	
IC6	CD4093BE		(QW53H)	IC15,16	CEM 3340		2 off		
TR3	2N3819		(QR36P)	IC17	CD4093BE			(QW53H)	
TR4	BC182L		(QB55K)	IC18	CD4013BE			(QX07H)	
TR5	BC212L		(QB60Q)	TR15	BC212L			(QB60Q)	
D11-D19 (no D15)	1N4148	8 off	(QL80B)	TR16,17	2N3819		2 off	(QR36P)	
Miscellaneous									
	8 pin DIL socket	3 off	(BL17T)	D28	Red LED			(WL27E)	
	14 pin DIL socket		(BL18U)	D29,30	1N4148		2 off	(QL80B)	
JK1,3	3.5mm jack socket	2 off	(HF82D)	Miscellaneous					
	PCB		(GA55K)	S3-10	Rotary switch 2-pole 6-way		8 off	(FF74R)	
	Veropins		(FL24B)	RV7,13	Joystick, 100k lin. pots.		4 off	(XB09K)	
				JK2,4,5,6	3.5mm jack socket		4 off	(HF82D)	
					8 pin DIL socket		4 off	(BL17T)	
					14 pin DIL socket		2 off	(BL18U)	
					16 pin DIL socket		2 off	(BL19V)	
					PCB			(GA36P)	
					Veropins			(FL24B)	

VCO PARTS LIST

Resistors — 5% ½W carbon unless specified			
R77,89	27k 1% film	2 off	(T27K)
R86,87,149,			
150,176,178	1M0 1% film	6 off	(T1M0)
R88	110k 1% film		(T110K)
R90,143,210,211	10k	4 off	(M10K)
R133	3k9 1% film		(T3K9)
R134,135,136,			
137	2k4 1% film	4 off	(T2K4)
R138	3k0 1% film		(T3K0)
R139	56k		(M56K)
R140-142,144,			
152-161,174,			
180,187,188,			
192,198-200,			
205-207	100k	25 off	(M100K)
R145	240k 1% film		(T240K)
R146,166,167	220k 1% film	3 off	(T220K)
R147,148	91k 1% film	2 off	(T91K)
R151	2M2 10%		(M2M2)
R162,163	100k 1% film	2 off	(T100K)
R164,165	47k 1% film	2 off	(T47K)
R168,171	24k 1% film	2 off	(T24K)
R169,172	910R ½W	2 off	(S910R)

FILTER BOARD PARTS LIST

Resistors — 5% ½W carbon unless specified									
R193,229	33k	2 off	(M33K)						
R194,242,257	1k0	3 off	(M1K0)						
R216,239	15k	2 off	(M15K)						
R217	39k		(M39K)						
R218	30k ½W		(S30K)						
R219,223,226,									
231,250,253,									
259,261,265,									
269,270	100k	11 off	(M100K)						
R220,221	300k ½W	2 off	(S300K)						
R222	620k ½W		(S620K)						
R224,245,246,									
247	1M0	4 off	(M1M0)						
R225,230,266	470k	3 off	(M470K)						
R227	1k8		(M1K8)						
R228	680k		(M680K)						
R232	220k		(M220K)						
R233,234	100R	2 off	(M100R)						
R235	18k		(M18K)						
R236,238	47k	2 off	(M47K)						
R237	22k		(M22K)						
R240	4k7		(M4K7)						
R241,243	27k	2 off	(M27K)						
R244	5k6		(M5K6)						

R248,252	120k	2 off	(M120K)
R249,251,256, 260,267	91k 1/2W	5 off	(S91K)
R254	330k		(M330K)
R255	51k 1/2W		(S51K)
R258	1k5		(M1K5)
R262,263	240k 1/2W	2 off	(S240K)
R264,272	56k	2 off	(M56K)
R268	180k		(M180K)
R271	150k		(M150K)
RV31,36,39,40	100k lin. pot.	4 off	(FW05F)
RV32	100k log. pot.		(FW25C)
RV33	100k min. horiz. preset		(WR61R)
RV34,35	10k min. horiz. preset	2 off	(WR58N)
RV37	50k cermet preset		(WR43W)
RV38	47k log. pot.		(FW24B)

Capacitors			
C39	100pF ceramic		(WX56L)
C40	1uF polycarb.		(WW53H)
C41	100nF polycarb.		(WW41U)
C42,47	1u0 100V PC elect.	2 off	(FF01B)
C43,46	100pF polystyrene	4 off	(BX28F)
C48,49	10uF 35V PC elect.	2 off	(FF04E)

Semiconductors			
IC20	1458C		(QH46A)
IC21,23,26	741C	3 off	(QL22Y)
IC22	CA3080E		(YH58N)
IC24	LF353 or TL082		(WQ31J)
IC25	CEM 3320		
TR12,13,14	BC182L	3 off	(QB55K)
D33,34,35	1N4148	3 off	(QL80B)

Miscellaneous			
S11,13	Rotary switch 2-pole 6-way	2 off	(FF74R)
S12	Rotary switch 4-pole 3-way		(FF76H)
JK7	3.5mm jack socket		(HF82D)
	8 pin DIL socket	6 off	(BL17T)
	18 pin DIL socket		(HQ76H)
	PCB		(GA57M)
	Veropins		(FL24B)

LFO PARTS LIST

Resistors — 5% 1/2W carbon unless specified			
R91	220R		(M220R)
R92,100,103, 110,323	33k	5 off	(M33K)
R93,99,104,105, 106,116,117	10k	7 off	(M10K)
R94	56k		(M56K)
R95,118	47k	2 off	(M47K)
R96,108	1k0	2 off	(M1K0)
R97	180R		(M180R)
R98	4M7 10%		(M4M7)
R101,111,320, 321,322	39k	5 off	(M39K)
R108	1k8		(M1K8)
R107	10M 10%		(M10M)
R109	150k		(M150K)
R112	13k 1/2W		(S13K)
R113	270k		(M270K)
R114	390k		(M390K)
R115	75k 1/2W		(S75K)
R119	240k 1/2W		(S240K)
R120	120k		(M120K)
R121	24k 1/2W		(S24K)
R122,123	100k	2 off	(M100K)
R124	5k1 1/2W		(S5K1)
R125	27k		(M27K)
R126	18k		(M18K)
R127	30k 1/2W		(S30K)
R128	6k8		(M6K8)
R129	2k7		(M2K7)
R130	180K		(M180K)
R131	22k		(M22K)
R132	82k		(M82K)
RV6	220k log. pot.		(FW26D)
RV8	470k min. horiz. preset		(WR63T)

Capacitors — polycarbonate unless specified			
C15	330nF		(WW47B)
C16	220nF		(WW45Y)
C17,18	10nF	2 off	(WW29G)
C19	6n8		(WW27E)
C20	100nF		(WW41V)
C67,68	100uF 25V PC elect.	2 off	(FF11M)

Semiconductors			
IC8	LF351 or TL081		(WQ30H)
IC9,10,12	1458	3 off	(QH46A)
IC11	CA3140 (see text)		(QH29G)
TR6,8,17	BC212L	3 off	(QB60Q)
TR7	2N2646		(QR14Q)
TR9,11,16	BC182L	3 off	(QB55K)
TR10	2N3819		(QR36P)
D20	Red LED		(WL27E)
D21-27,D15	1N4148	8 off	(QL80B)
Miscellaneous			
	PCB		(GA53H)
	Veropins		(FL24B)
S2	Rotary switch 2-pole 6-way		(FF74R)

ENVELOPE SHAPER BOARD PARTS LIST

Resistors — 5% 1/2W carbon unless specified			
R273	62k 1/2W		(S62K)
R274,288	56k	2 off	(M56K)
R275,279,286, 289,290	150k	5 off	(M150K)
R276,277,313, 314	10k	4 off	(M10K)
R278	20k 1/2W		(S20K)
R280,291,303, 304,329	100R	5 off	(M100R)
R281	680R		(M680R)
R282	6k8		(M6K8)
R283,284,285, 287,292,294, 298,299,307	100k	9 off	(M100K)
R293,295,296, 301,318,319	47k	6 off	(M47K)
R297,300,302	1M	3 off	(M1M0)
R305	22k		(M22K)
R306	1k8		(M1K8)
R308	2k2		(M2K2)
R309,311	24k 1/2W	2 off	(S24K)
R310,312	750R 1/2W	2 off	(S750R)
R315	220k		(M220K)
R316	12k		(M12K)
R317	82k		(M82K)
R330	560R		(M560R)
RV41,43,44	100k min. horiz. preset	3 off	(WR61R)
RV42	4k7 lin. pot.		(FW01B)
RV45	4k7 log. dual gang pot.		(FX08J)
RV46,47,49,51, 52,54	10k lin. pot.	6 off	(FW02C)
RV48,53	100k lin. pot.	2 off	(FW05F)
RV50	47k min. horiz. preset		(WR60Q)

Capacitors — polycarbonate unless specified			
C50,53	1nF ceramic plate	2 off	(WX68Y)
C51,55	4n7	2 off	(WW26D)
C52	100pF ceramic plate		(WX56L)
C54	1u0 100V PC elect.		(FF01B)
C56,73	12pF ceramic plate	2 off	(WX46A)
C57	6n8		(WW27E)
C58,60	22nF	2 off	(WW33L)
C59,61	39nF	2 off	(WW36P)
C62	100nF		(WW41U)
C63,64	100uF 25V PC elect.	2 off	(FF11M)
C74,75,76	1u0	3 off	(WW53H)
C77	10u 35V PC elect.		(FF04E)

Semiconductors			
IC27,33	1458C	2 off	(QH46A)
IC28	CEM 3330		
IC29	LF347		(WQ29G)
IC30	741C		(QL22Y)
IC31,32	CEM 3310	2 off	
TR15	BC212L		(QB60Q)
D36,37,39,40	1N4148	4 off	(QL80B)
D38	Red LED		(WL27E)
D41	10V 400mW zener		(QH14Q)

Miscellaneous			
S14	Shaft assembly and 2-pole 6-way wafer	2 off	(FH46A)
	Rotary switch 2-pole 6-way		(FH48C)
S15	Rotary switch 2-pole 6-way		(FF74R)
JK8	3.5mm jack socket		(HF82D)
JK9,10,11	Standard mono jack socket	3 off	(BW78K)
	8 pin DIL socket	3 off	(BL17T)
	14 pin DIL socket		(BL18U)
	16 pin DIL socket	2 off	(BL19V)
	18 pin DIL socket		(HQ76H)
	PCB		(GA59P)

WIRING DETAILS

From	To	Remarks
PLA/L	FS 1/1	
PLA/N	S1a/1	
PLA/E	Earth tag 1	
FS1/	S1b/1	
S1a/2	T1/5	
S1b/2	T1/6	
T1/1	PSU/1	
T1/2	PSU/2	
T1/3	PSU/3	
T1/4	PSU/4	
PSU/5	Tag strip 2/3	
PSU/6	Tag strip 2/1	
PSU/7	Tag strip 2/2	
PSU/8	Earth tag 1	
Controller/1	Not used	
Controller/2	Not used	
Controller/3	JK1/1	
Controller/4	S15a/3	
Controller/5	S15a/2	Link to S15a/4
Controller/6	Not used	
Controller/7	JK3/1	
Controller/8	Tag strip/2	
Controller/9	Tag strip/1	
Controller/10	Tag strip/3	
Controller/11	Not used	
Controller/12	RV4/ccw	
Controller/13	VCO/98	
Controller/14	RV4/cw	Link to RV4/w
Controller/15	Keyboard contact/3	
Controller/16	Keyboard contact/4	
Controller/17	Keyboard contact/2	
Controller/18	Keyboard contact/1	
LFO/19	S5/1	
LFO/20	S5/3	
LFO/21	RV7/w	
LFO/22	RV7/1	Link to S5/2
LFO/23	S2b/C	
LFO/24	S2a/A	
LFO/25	S2a/6	
LFO/26	S2b/11	
LFO/27	S2b/12	
LFO/28	S2b/7	
LFO/29	S2b/10	
LFO/30	S2b/8	
LFO/31	S2b/9	
LFO/32	Tag strip 2/1	
LFO/33	Not used	
LFO/34	Tag strip 2/3	
LFO/35	Tag strip 2/2	
LFO/36	RV7/2	Link to D20/K
LFO/37	D20/a	
LFO/38	RV6/ccw	
LFO/39	RV6/w	
LFO/40	RV6/cw	
LFO/41	S15a/6	
VCO/42	JK6/1	
VCO/43	Not used	
VCO/44	Filter/107	
VCO/45	Filter/106	
VCO/46	S10/5	
VCO/47	S10/6	
VCO/48	S10/3	
VCO/49	S10/2	
VCO/50	S10/1	
VCO/51	S9/5	
VCO/52	S9/6	
VCO/53	S9/1	
VCO/54	S9/2	
VCO/55	S9/3	
VCO/56	D28/K	
VCO/57	Not used	
VCO/58	RV25/w	
VCO/59	RV16/w	
VCO/60	S7/1	
VCO/61	S7/3	
VCO/62	S7/4	
VCO/63	S7/5	
VCO/64	RV15/ccw	
VCO/65	Not used	
VCO/66	S3/6	Link to S4/6
VCO/67	S3/5	Link to S4/5
VCO/68	S3/4	Link to S4/4
VCO/69	S3/3	Link to S4/3
VCO/70	S3/2	Link to S4/2
VCO/71	S3/1	Link to S4/1
VCO/72	Not used	

VCO/73	S3/A		Envelope/140	RV53/w	
VCO/74	S4/A		Envelope/141	RV52/w	
VCO/75	Not used		Envelope/142	RV54/w	
VCO/76	S6/6		Envelope/143	RV51/w	
VCO/77	S6/5		Envelope/144	RV53/cw	
VCO/78	S6/4		Envelope/145	RV48/w	
VCO/79	S6/2		Envelope/146	RV47/w	
VCO/80	RV14/ccw		Envelope/147	RV49/w	
VCO/81	RV14/cw	Link to JK5/1	Envelope/148	RV46/w	
VCO/82	RV13/w		Envelope/149	RV48/cw	
VCO/83	RV26/cw	Link to RV25/ccw	Envelope/150	S15a/A	
VCO/84	RV26/w		Envelope/151	S15b/C	
VCO/85	RV26/ccw		Envelope/152	S15b/10,11	
VCO/86	JK4/1		Envelope/153	D38/K	
VCO/87	S8b/8	Link to S8b/10	Envelope/154	S13/4	
VCO/88	S8b/7		Envelope/155	S13/5	
VCO/89	Not used		Envelope/156	RV46,47,49,51,52,54/cw	
VCO/90	S8b/11	Link to S8b/9	Envelope/157	RV46,47,48,49,51,52,53,54/ccw, D38a	
VCO/91	S8a/5	Link to S8a/4	Envelope/158	RV42/cw	
VCO/92	S8a/1	Link to S8a/2 & 3	Envelope/159	RV42/cw	
VCO/93	Not used		Envelope/160	Tag strip 2/1	
VCO/94	RV28/ccw	Screen	Envelope/161	Tag strip 2/2	
VCO/95	RV28/w	Conductor *	Envelope/162	Tag strip 2/3	
VCO/96	Not used		Envelope/163	S14a/Wiper	
VCO/97	RV5/w		Envelope/164	S14b/Wiper	
VCO/99	RV40/cw	Link to JK2/1	Envelope/165	S14b/5b	Link to RV45a & b/ccw
VCO/100	Not used				
VCO/101	Tag strip 2/1		Envelope/166	S14b/6b	
VCO/102	RV16/cw		Envelope/167	S14b/1b,2b,3b,4b	
VCO/103	Tag strip 2/3		Envelope/168	JK10/1	Conductor *
VCO/104	RV16/ccw		Screen not used	JK10/2	Screen
VCO/105	Tag strip 2/2		Envelope/169	JK11/1	Conductor *
Filter/108	Not used		Envelope/171	JK11/2	Screen
Filter/109	RV31/cw		Envelope/170	JK9/1	Conductor *
Filter/110	RV31/ccw		Screen not used	JK9/2	Screen
Filter/111	RV31/w		Envelope/172	RV45a/w	
Filter/112	RV32/cw		Envelope/173	RV45b/w	
Filter/113	RV32/ccw		Envelope/174	S14c/3c,4c,5c,6c	
Filter/114	RV32/w		Envelope/175	RV45b/cw	
Filter/115	S11a/A		Envelope/176	RV45a/cw	
Filter/116	S11b/C		Envelope/177	JK8/1	
Filter/117	S11a/5		Envelope/179	RV42/W	
Filter/118	S11a/1,2,3				
Filter/119	JK7/1		JK1-8 incl/2	Tag strip 2/1	
Filter/120	S9 & S10/A	Conductor *	S5/1	S11b/7, S13/1	
	Not used	Screen	S5/2	S11b/8, S13/2, S14a/1a,3a	
Filter/121	Envelope/178		S5/3	S11b/5, S13/3, S14a/2a,4a	
Filter/122	S12a/A	Link to S12b/5,6	RV16/cw	D28a, RV5/ccw, RV13/2	
Filter/123	S12a/1		RV16/ccw	RV5/cw, 58b/c, RV25/cw, RV13/1	
Filter/124	S12b/B		RV14/w	S6/A	
Filter/125	S12c/C		RV15/cw	S5/A	
Filter/126	S12c/9	Link to S12d/10,11	RV15/w	S7/A	
Filter/127	S12b/4		RV28/cw	S8a/A	
Filter/128	Not used		RV25/ccw	To screen of S9 & S10/w only	
Filter/129	S12c/7,8		RV32/ccw	RV40/ccw, RV39/ccw, RV36/ccw,	
Filter/130	S12d/12			RV38/ccw	
Filter/131	RV38/w		S12b/4	S12d/D, S11a/4,6, S11b/10	
Filter/132	RV40/w		RV31/ccw	S2a/5, S5/6, S13/6	
Filter/133	RV39/w		RV38/cw	S13/A	
Filter/134	S6/1		JK9/2	JK10/2, JK11/2	
Filter/135	RV36/w	Link to RV39/cw,	JK9/1	S14c/1c,2c	Conductor *
Filter/136	RV36/cw	S15a/1a,5a	JK9/2	Screen not used	Screen
			JK10/1	S14c/Wiper	Conductor *
Filter/137	Tag strip 2/1		JK10/2	Screen not used	Screen
Filter/138	Tag strip 2/3		S13/4	S11b/11, S5/4	
Filter/139	Tag strip 2/2		S13/5	S11b/12, S5/5	

* Screened Lead